

# Filament Wound

High Load

Self-lubricating Bearings

Designer's Handbook



***Thyssing Industrial Supplies Pty Ltd***

ABN 63 099 806 283

PO Box 3072, Ivanhoe North, Victoria 3079, Australia

136-138 Plenty Road, Preston, Victoria 3072, Australia

Ph: +61 3 9484 9550

Fax: +61 3 9484 9755

web: [www.thyssing.com.au](http://www.thyssing.com.au)

email: [info@thyssing.com.au](mailto:info@thyssing.com.au)



# Quality

All the products described in this handbook are manufactured under ISO/TS 16949 and ISO 14001 approved quality management systems.



## ZERTIFIKAT

Die **DQS GmbH**  
Deutsche Gesellschaft zur Zertifizierung von Managementsystemen  
bescheinigt hiermit, dass das Unternehmen

**GGB GERMANY GMBH & CO. KG**

Ochsenbrunnstraße 9  
D-74078 Heilbronn

Für den Geltungsbereich

Herstellung und Vertrieb von Getrieben für die Automobilindustrie  
und andere industrielle Anwendungsbereiche mit Entwicklung bei  
GGB France E.U.S.L. in Anney, Frankreich.

ein  
**Qualitätsmanagementsystem**  
eingeführt hat und anwendet.

Durch ein Audit, dokumentiert in einem Bericht, wurde in Übereinstimmung  
mit den Zertifizierungsregeln der Automobilindustrie für ISO/TS 16949:2002,  
der Nachweis erbracht, dass dieses Qualitätsmanagementsystem die Forderungen  
der folgenden Technischen Spezifikationen einschließlich ISO 9001:2000 erfüllt

**ISO/TS 16949:2002**  
2. Ausgabe März 2002

(mit Produktentwicklung)

Zertifizierungsaudit: 2004-02-09 - 2004-02-13  
Zertifizierungsüberprüfung: 2005-03-07  
Dieses Zertifikat ist gültig bis: 2007-03-11  
Zertifikat-Registrier-Nr.: 002772 152/02523  
Frankfurt am Main: 2005-03-07

*Ulrich*  
Hr. M. Dietrich

*Herrlich*  
Drs. Ing. S. Heintz

D-60493 Frankfurt am Main, August-Straße 21  
(Tel. +49-69-95-62 70)



## ZERTIFIKAT

Die **DQS GmbH**  
Deutsche Gesellschaft zur Zertifizierung von Managementsystemen  
bescheinigt hiermit, dass das Unternehmen

**GGB GERMANY  
GMBH & CO. KG**

Ochsenbrunnstraße 9  
D-74078 Heilbronn

Für den Geltungsbereich

Herstellung und Vertrieb von Getrieben für die Automobilindustrie  
und andere industrielle Anwendungsbereiche mit Entwicklung bei  
GGB France E.U.S.L. in Anney, Frankreich.

ein  
**Umweltmanagementsystem**  
eingeführt hat und anwendet.

Durch ein Audit, dokumentiert in einem Bericht, wurde der  
Nachweis erbracht, dass dieses Umweltmanagementsystem  
die Forderungen der folgenden Norm erfüllt:

**DIN EN ISO 14001 : 2005**  
Ausgabe November 2004

Dieses Zertifikat ist gültig bis: 2007-03-11  
Zertifikat-Registrier-Nr.: 002772 UM  
Frankfurt am Main: 2005-03-03

*Ulrich*  
Hr. M. Dietrich

*Herrlich*  
Drs. Ing. S. Heintz

D-60493 Frankfurt am Main, August-Straße 21



## CERTIFICAT AF AQ CERTIFICATE



N° TS/2003/21286

N° IATF : 0017381

AF AQ certifie que le système qualité décrit par  
AF AQ certifies that the quality system described by

**GLACIER GARLOCK BEARINGS**

pour les activités suivantes  
for the following activities

CONCEPTION, INDUSTRIALISATION, FABRICATION ET VENTE  
DE SYSTEMES ANTI-FRICTION.

INDUSTRIALISATION, FABRICATION ET VENTE  
DE PALIERS DE POMPES HYDRAULIQUES A ENGRENAGES.

DESIGN, DEVELOPMENT, MANUFACTURING AND SALES  
OF ANTI-FRICTION SYSTEMS.

DEVELOPMENT, MANUFACTURING AND SALES  
OF HYDRAULIC GEAR PUMP BEARINGS BLOCKS.

65, chemin de la prairie BP n°2074 F-74009 ANNECY  
Route de Saint-Avoid Zone Industrielle F-57260 DIEULOU  
22-28, rue Henri Barbusse F-92210 CLICHY  
(Liste des sites en annexe n° 1 à n° 2)  
(List of locations on appendices n° 1 to n° 2)

à été audité selon les "Règles pour les certificats sous le régime ISO/TS 16949:2002"  
has been assessed in accordance with "The rules for the certificates under the assessment application from ISO/TS 16949"

**ISO/TS 16949 : 2002**

Chapitre de l'ISO/TS 16949:2002 énonçant les applications 7.3 (évaluation de la conception des processus de fabrication)  
The ISO/TS 16949:2002 chapter which sets out application 7.3 (assessment of manufacturing process design)

Néant

Le présent certificat, délivré dans les conditions fixées par AF AQ, est valide à date de:  
This certificate, delivered under AF AQ, is valid as of:

2003-11-07

2006-11-06

(année/mois/jour) (year/mo/day)

Le Président du Comité de Certification Le Directeur Général d'AF AQ Le Représentant de  
The President of the Certification Committee The Managing Director of AF AQ On Behalf of

*M. FONDEVOLLE* *G. PEYRAT* *A. ZATTI*

AF AQ - 118, AVENUE ARISTIDE BRUNEL - BP 401 - F-93533 BOULIERES COEXE FRANCE

## UNDERWRITERS LABORATORIES INC. CERTIFICATE OF REGISTRATION

**Glacier Garlock Bearings, LLC**  
700 Mid Atlantic Parkway  
Thorofare, NJ 08086

Underwriters Laboratories Inc.® (U.L.), Melville, NY, USA, issues this certificate to the Firm named above (and where applicable in the annexes) to this certificate), after assessing the Firm's quality system and finding it in compliance with

**ISO/TS 16949: 2002**

Having been audited in accordance with the "Rules for the registration scheme for ISO/TS16949: 2002 - First Edition".

for the following scope of registration

3562 (US) : Ball and Roller Bearings

The design and manufacture of steel-backed bearings. The design and manufacture of filament wound bearings and washers. The remote location at Ochsenbrunnstraße 9, D-74078 Heilbronn, Germany performs the following primary functions: sales to Visteon (Europe).

Exclusions: None

This quality system registration is included in U.L.'s Directory of Registered Firms and applies to the provision of goods and/or services as specified in the scope of registration from the address(es) shown above. By issuance of this certificate the firm represents that it will maintain its registration in accordance with the applicable requirements. This certificate is not transferable and remains the property of Underwriters Laboratories Inc.®.

File Number: A4360

Volume: 2 of 2

Page 1 of 3

ISO/TS 16949:2002 Issue Date: October 23, 2004

Revision Date: October 23, 2004

Renewal Date: October 22, 2007

*S. Joe Shatta*  
S. Joe Shatta  
Executive Vice President, International



Certificate Number 0020621



## CERTIFICATION AF AQ



N° ENV/2003/21538

Le Système de Management Environnemental adopté par:  
The Environmental Management System developed by:

**GLACIER GARLOCK BEARINGS**

pour les activités suivantes:  
for the following activities:

INDUSTRIALISATION, FABRICATION ET VENTE  
DE SYSTEMES ANTI-FRICTION.

INDUSTRIALIZATION, MANUFACTURING AND SALES  
OF ANTI-FRICTION SYSTEMS.

65, chemin de la prairie BP n°2074 F-74009 ANNECY  
22/28, rue Henri Barbusse F-92210 CLICHY

a été audité et jugé conforme aux exigences de la norme:  
has been assessed and found to conform to the requirements of the standard:

**ISO 14001 (1996)**

2003-12-29

2006-12-28

(année/mois/jour) (year/mo/day)

Le Président du Comité de Certification Le Directeur Général d'AF AQ Le Représentant de  
The President of the Certification Committee The Managing Director of AF AQ On Behalf of

*P. SCHWARTZMANN* *G. PEYRAT* *A. ZATTI*

AF AQ - 118, AVENUE ARISTIDE BRUNEL - BP 401 - F-93533 BOULIERES COEXE FRANCE

## UNDERWRITERS LABORATORIES INC. ENVIRONMENTAL MANAGEMENT SYSTEM REGISTRATION

**GGB LLC**  
P.O. Box 189  
700 Mid-Atlantic Parkway  
Thorofare, NJ 08086

With Remote locations at:  
1451 Metropolitan Avenue  
Thorofare, New Jersey 08086  
U.S.A.

Underwriters Laboratories Inc.® (U.L.) issues this certificate to the Firm named above, after assessing the Firm's environmental management system and finding it in compliance with

**ISO 14001:1996**  
ENVIRONMENTAL MANAGEMENT SYSTEM

for the following scope of registration

The environmental management system of GGB LLC associated with the design and manufacture of self-lubricated metal back bearings at 700 Mid-Atlantic Parkway; Thorofare, New Jersey, U.S.A.  
The remote location at 1451 Metropolitan Avenue, Thorofare, New Jersey, U.S.A. performs the following primary functions: the manufacture of filament-wound self-lubricating bearings.

This environmental management system registration is included in U.L.'s Directory of Registered Firms and applies to the operations of the address(es) shown above. By issuance of this certificate the firm represents that it will maintain its registration in accordance with the applicable requirements. This certificate is not transferable and remains the property of Underwriters Laboratories Inc.®.

File Number: A12129

Volume: 1

Original Certification Date: October 31, 2003

ISO 14001 Issue Date: October 31, 2003

Revision Date: October 6, 2004

Renewal Date: October 30, 2006

*S. Joe Shatta*  
S. Joe Shatta  
Executive Vice President, International



## Formula Symbols and Designations

Formula Symbol	Unit ANSI	Unit SI	Designation
$a_B$	-	-	Bearing size factor
$a_E$	-	-	High load factor
$a_M$	-	-	Mating material factor
$a_S$	-	-	Surface finish factor
$a_T$	-	-	Temperature application factor
$B$	inch	mm	Nominal bush length
$C_D$	inch	mm	Installed diametral clearance
$D_H$	inch	mm	Housing Diameter
$D_I$	inch	mm	Nominal bush ID Nominal thrust washer ID
$D_o$	inch	mm	Nominal bush OD Nominal thrust washer OD
$D_J$	inch	mm	Shaft diameter
$F$	lbs.	N	Bearing load
$\mu$	-	-	Coefficient of friction
$L_Q$	-	-	Bearing service life, cycles
$N$	1/min	1/min	Rotational speed
$N_{osc}$	1/min	1/min	Rotational speed for oscillating motion
$P$	psi	N/mm <sup>2</sup>	Specific load
$P_{lim}$	psi	N/mm <sup>2</sup>	Specific load limit
$P_{sta,max}$	psi	N/mm <sup>2</sup>	Maximum static load
$P_{dyn,max}$	psi	N/mm <sup>2</sup>	Maximum dynamic load
$Q_{GF}$	-	-	GAR-FIL cyclic life factor
$Q_{GM}$	-	-	GAR-MAX and HSG cyclic life factor
$Q_{MLG}$	-	-	MLG cyclic life factor
$R_a$	$\mu$ inch	$\mu$ m	Surface roughness (DIN 4768, ISO/DIN 4287/1)
$S_m$	psi	N/mm <sup>2</sup>	Calculated edge stress
$S_S$	inch	mm	Thickness of slideplate
$S_T$	inch	mm	Thickness of washer
$s$	inch	mm	Bush wall thickness
$T$	°F	°C	Temperature
$T_{amb}$	°F	°C	Ambient temperature
$T_{max}$	°F	°C	Maximum temperature
$T_{min}$	°F	°C	Minimum temperature

Formula Symbol	Unit ANSI	Unit SI	Designation
$V$	fpm	m/s	Sliding speed
$V_{lim}$	fpm	m/s	Maximum sliding speed
$\alpha_1$	1/10°K	1/10°K	Coefficient of linear thermal expansion
$\sigma_c$	psi	N/mm <sup>2</sup>	Compressive Yield strength
$\lambda_B$	BTU-in/hr-ft <sup>2</sup> ·°F	W/mK	Thermal conductivity of bearing material
$\phi$	°	°	Angular displacement

### Unit Conversions

#### SI to ANSI Conversions

1 mm	0.0394 inch
1 Newton = 1N	0.225 lbs.
1 N/mm <sup>2</sup> = 1 MegaPascal	145 psi
1 m/s	196.85 fpm
°C	(°F-32)/1.8

#### ANSI to SI Conversions

1 inch	25.4 mm
1 Lb.	4.448 Newtons
1 psi	0.0069 N/mm <sup>2</sup> = 0.0069 MegaPascal
1 fpm	0.0051 m/s
°F	(1.8 x °C) +32

mm = millimeters

ft = foot

in = inch

N = Newtons

W = Watts

Lbs. = pounds

psi = pounds per square inch

hr = hour

fpm = feet per minute

m/s = meters per second

°F = degrees Fahrenheit

°C = degrees Celsius

K = degrees Kelvin

BTU = British Thermal Units

## Content

Quality . . . . .	I	<b>5 Performance . . . . .</b>	<b>22</b>
Formula Symbols and Designations . . . . .	II	<b>5.1 Design Factors . . . . .</b>	<b>22</b>
<b>1 Introduction . . . . .</b>	<b>4</b>	<b>5.2 Specific Load, P . . . . .</b>	<b>22</b>
<b>1.1 General Characteristics and Advantages . . . . .</b>	<b>4</b>	<b>5.3 Sliding Speed, V . . . . .</b>	<b>23</b>
<b>Wide Application Range . . . . .</b>	<b>4</b>	<b>5.4 PV Factor . . . . .</b>	<b>23</b>
<b>Low Friction Operation . . . . .</b>	<b>5</b>	<b>5.5 Estimating Bearing Life . . . . .</b>	<b>24</b>
<b>Outstanding Dimensional Stability . . . . .</b>	<b>5</b>	Cyclic Bearing Life, $L_Q$ . . . . .	24
<b>Wide Range of Sizes and Shapes . . . . .</b>	<b>5</b>	High Load Factor, $a_E$ . . . . .	24
		Temperature Factor - $a_T$ . . . . .	26
		Mating Material Factor - $a_M$ . . . . .	26
		Mating Surface Factor - $a_S$ . . . . .	27
		Bearing Size Factor - $a_B$ . . . . .	27
<b>2 Material Description . . . . .</b>	<b>6</b>	<b>5.6 Worked Examples . . . . .</b>	<b>29</b>
<b>2.1 GAR-MAX® . . . . .</b>	<b>6</b>	<b>5.7 Misalignment . . . . .</b>	<b>31</b>
<b>2.2 GAR-FIL® . . . . .</b>	<b>7</b>	<b>6 Installation and Machining . . . . .</b>	<b>33</b>
<b>2.3 Special GAR-MAX® Products HSG™ and MLG™ . . . . .</b>	<b>8</b>	<b>6.1 Installation . . . . .</b>	<b>33</b>
<b>2.4 Hydropower Products HPM™ and HPF™ . . . . .</b>	<b>9</b>	<b>6.2 Machining . . . . .</b>	<b>33</b>
<b>2.5 MEGA LIFE® XT Thrust Bearings . . . . .</b>	<b>10</b>	Length . . . . .	33
<b>2.6 Performance Comparison Chart . . . . .</b>	<b>11</b>	Outer Diameter . . . . .	33
		Inner Diameter . . . . .	33
		Deburring . . . . .	33
		Drilling . . . . .	33
<b>3 Properties . . . . .</b>	<b>12</b>	<b>7 Standard Products . . . . .</b>	<b>34</b>
<b>3.1 Physical Properties . . . . .</b>	<b>12</b>	<b>7.1 GF, GM, HSG, MLG (inch sizes) . . . . .</b>	<b>34</b>
<b>3.2 Performance Comparison . . . . .</b>	<b>13</b>	1/8" wall series . . . . .	34
<b>3.3 Chemical Resistance . . . . .</b>	<b>14</b>	1/4" wall series . . . . .	36
<b>4 Data for Designers . . . . .</b>	<b>16</b>	<b>7.2 GF, GM, HSG, MLG (metric sizes) . . . . .</b>	<b>38</b>
<b>4.1 Wear Rate . . . . .</b>	<b>16</b>	2.5 mm wall series . . . . .	38
<b>4.2 Frictional Properties . . . . .</b>	<b>17</b>	5 mm wall series . . . . .	40
<b>4.3 Operating Temperature . . . . .</b>	<b>18</b>	<b>7.3 MEGALIFE XT, Thrust Bearings, Inch sizes . . . . .</b>	<b>42</b>
<b>4.4 Load Capacity . . . . .</b>	<b>18</b>	<b>7.4 MEGALIFE XT, Thrust Bearings, Metric sizes . . . . .</b>	<b>43</b>
<b>4.5 Surface Velocity . . . . .</b>	<b>19</b>	<b>8 Data Sheet . . . . .</b>	<b>44</b>
<b>4.6 PV Factor . . . . .</b>	<b>19</b>	<b>8.1 Data for bearing design calculations . . . . .</b>	<b>44</b>
<b>4.7 Operating Clearances . . . . .</b>	<b>20</b>	<b>9 Other GGB Bearing Materials . . . . .</b>	<b>45</b>
<b>4.8 Dimensional Considerations . . . . .</b>	<b>20</b>		
<b>4.9 Shaft Material and Surface Finish . . . . .</b>	<b>21</b>		
<b>4.10 Housing Material . . . . .</b>	<b>21</b>		
<b>4.11 Lubrication . . . . .</b>	<b>21</b>		

## 1 Introduction

The purpose of this handbook is to provide comprehensive technical information on the characteristics of GGB's family of filament wound, high load, self-lubricating bearings. The information given permits designers to establish the appropriate material required for a particular application. GGB North America (GGBNA) applications and development engineering services are available to assist with unusual design problems.

GGB is the world's largest manufacturer of polymer plain bearings for low maintenance and maintenance free applications. This includes an extensive product portfolio including metal-polymer bearings, thermoplastic materials, filament wound com-

posite materials and mono metallic materials.

GGBNA, is one of six GGB manufacturing facilities world wide, and has remained the foremost supplier of self-lubricating plain bearings to America's industrial and automotive markets for almost 30 years. GGB is continually refining and extending its experimental and theoretical knowledge and, therefore, when using this brochure it is always worthwhile to contact GGB if additional information should be required.

As it is impossible to cover all conditions of operation that arise in practice, customers are advised to conduct prototype testing wherever possible.

### 1.1 General Characteristics and Advantages

To meet the need for high load, self-lubricating bearings that provide low wear rates in a wide variety of applications, GGB has developed a comprehensive family of filament wound, composite self-lubricating bearing materials. These bearings combine the excellent lubricating properties of filled PTFE (polytetrafluoroethylene) with

the high strength and stability of an oriented glass fiber wound structure. GGB's Filament wound bearings employ a tough, high strength composite structure consisting of epoxy-impregnated, wound glass fibers oriented to provide the radial and axial strength required to support high bearing loads.

**GAR-MAX<sup>®</sup>** and **HSG<sup>™</sup>** (High Strength GAR-MAX<sup>®</sup>) have a bearing surface liner of PTFE and high strength fibers twisted together and encapsulated by a high temperature epoxy resin that has been further enhanced with a self-lubricating additive.

**MLG<sup>™</sup>** has a bearing surface liner of PTFE and high strength fibers twisted together and encapsulated by a high temperature resin.

**GAR-FIL<sup>®</sup>** has a proprietary filled PTFE tape liner bonded to the backing.

**HPM<sup>™</sup>** has a bearing surface liner of PTFE and high strength fibers twisted together and encapsulated by a high temperature epoxy resin that has been further enhanced with PTFE.

**HPF<sup>™</sup>** has a bearing surface liner consisting of a proprietary filled PTFE tape liner bonded to the backing.

**MEGALIFE<sup>®</sup> XT** Thrust washers have a proprietary filled PTFE surface on both sides of the washers supported by a high strength composite inner core.

#### Wide Application Range

Laboratory and field testing have proven that GGB filament wound bearings provide outstanding performance in a wide variety of demanding dry or lubricated bearing applications. These include off-road vehicles, agricultural and automotive equip-

ment, construction equipment, aerial lifts, windmills, materials handling equipment, valves, textile equipment, mechanical and hydraulic presses, waste/recycling equipment, processing equipment, packing machinery, and many more.

## Low Friction Operation

GGB self-lubricating filament wound bearings are particularly effective in applications where the relative motion is not sufficient to promote circulation of the oil or grease used with more conventional bearings. The natural lubricity of the PTFE

used in the bearing surfaces assures low friction in dry applications. In fact, in low speed, high pressure type applications. GAR-FIL bearings offer one of the lowest coefficients of friction of any self-lubricated bearing material.

## Outstanding Dimensional Stability

Unlike many conventional non metallic bearing materials, the high strength composite bearing structure of GGB filament wound bearings offer a thermal expansion rate similar to that of steel. This assures maximum dimensional stability and posi-

tive housing retention, even at elevated temperatures. Furthermore, GGB filament wound bearings are dimensionally stable in water. Water absorption and swell are negligible.

## Wide Range of Sizes and Shapes

GGB filament wound bearings are available in standard sizes from 12 mm to 150 mm [1/2" to 6"] ID with wall thicknesses of 2.5 mm and 5 mm [1/8" and 1/4"], including lengths up to 400 mm [16"]. On special order, ID sizes from 10 mm to over 500 mm [3/8" to over 20"] can be furnished with custom wall thickness and/or length as required.

MEGALIFE® XT thrust bearings are available in standard sizes with custom sizes available upon request.

Special shapes based on customer requirements are possible as shown below. Contact GGB for details.

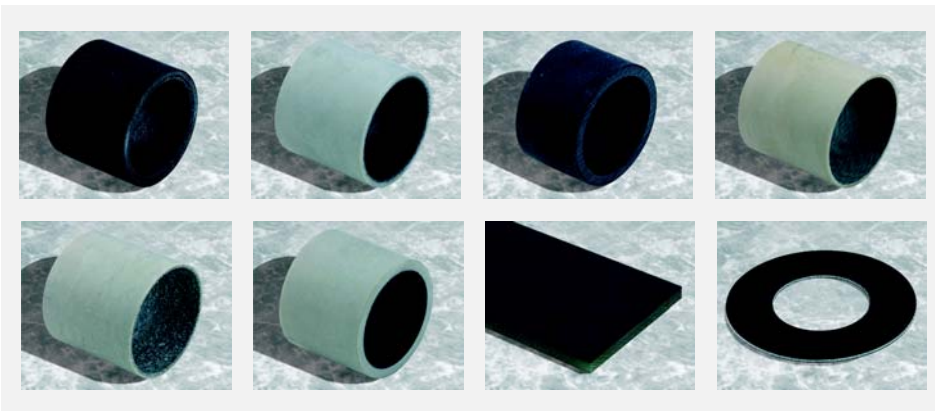

Fig. 1: Standard Shapes



Fig. 2: Examples for Special Shapes

## 2 Material Description

### 2.1 GAR-MAX®

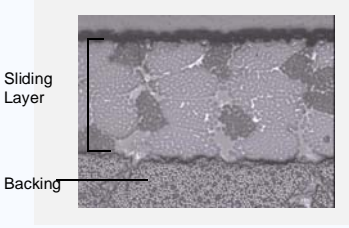
Structure	Sliding Layer Microsection
<p><b>Sliding layer</b> Continuous wound PTFE and high-strength fibers encapsulated in an internally lubricated, high temperature filled epoxy resin.</p> <p><b>Backing</b> Continuous wound fiberglass encapsulated in a high temperature epoxy resin.</p>	

Features	Possible Applications	Availability
<ul style="list-style-type: none"> <li>• High load capacity</li> <li>• Excellent shock resistance</li> <li>• Excellent misalignment resistance</li> <li>• Excellent contamination resistance</li> <li>• Very good friction and wear properties</li> <li>• Good chemical resistance</li> </ul>	<ul style="list-style-type: none"> <li>• Steering linkages</li> <li>• hydraulic cylinder pivots</li> <li>• king pin bearings</li> <li>• boom lifts, scissor lifts</li> <li>• cranes, hoists, lift gates</li> <li>• backhoes, trenchers</li> <li>• skid steer loaders</li> <li>• front end loaders...</li> </ul>	<p><b>Standard</b> Cylindrical bearings: ID Range: 12 to 150 mm, metric series; 0.5 to 6 inch, inch series.</p> <p><b>Special order</b> Bearing diameters to 500 mm [20 inches]; flanged bearings; hex and square bores; liner on OD</p>

Bearing Properties	SI Unit Value	ANSI Unit Value
<b>Ultimate Compressive strength <math>\sigma_c</math></b>	414 N/mm <sup>2</sup>	60,000 psi
<b>Maximum static load <math>P_{sta,max}</math></b>	207 N/mm <sup>2</sup>	30,000 psi
<b>Maximum dynamic load <math>P_{dyn,max}</math></b>	138 N/mm <sup>2</sup>	20,000 psi
<b>Maximum sliding speed <math>V_{lim}</math></b>	0.13 m/s	25 fpm
<b>Maximum PV factor</b>	1.05 N/mm <sup>2</sup> ·m/s	30,000 psi·fpm
<b>Maximum temperature <math>T_{max}</math></b>	163 °C	325 °F
<b>Minimum temperature <math>T_{min}</math></b>	-196 °C	-320 °F

## 2.2 GAR-FIL®

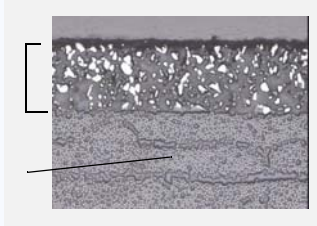
Structure	Sliding Layer Microsection
<p><b>Sliding layer</b> Proprietary filled PTFE tape liner, 0.38 mm [.015] standard thickness.</p> <p><b>Backing</b> Continuous wound fiberglass encapsulated in a high temperature epoxy resin.</p>	

Features	Possible Applications	Availability
<ul style="list-style-type: none"> <li>• High load capacity</li> <li>• Good chemical resistance</li> <li>• Machinable bearing surface</li> <li>• High rotational speed capability</li> <li>• Very good friction and wear properties</li> <li>• Excellent contamination resistance</li> </ul>	<ul style="list-style-type: none"> <li>• Valves</li> <li>• scissor lifts</li> <li>• pulleys</li> <li>• toggle linkages...</li> </ul>	<p><b>Standard</b> Cylindrical bearings: ID Range: 12 to 150 mm, metric series; 0.5 to 6 inch, inch series.</p> <p><b>Special order</b> Bearing diameters to 500 mm [20 inches]; special tape thicknesses; flanged bearings; hex and square bores; liner on OD</p>

Bearing Properties	SI Unit Value	ANSI Unit Value
<b>Ultimate Compressive strength <math>\sigma_c</math></b>	379 N/mm <sup>2</sup>	55,000 psi
<b>Maximum static load <math>P_{sta,max}</math></b>	138 N/mm <sup>2</sup>	20,000 psi
<b>Maximum dynamic load <math>P_{dyn,max}</math></b>	138 N/mm <sup>2</sup>	20,000 psi
<b>Maximum sliding speed <math>V_{lim}</math></b>	2.50 m/s	500 fpm
<b>Maximum PV factor</b>	1.23 N/mm <sup>2</sup> ·m/s	35,000 psi·fpm
<b>Maximum temperature <math>T_{max}</math></b>	204 °C	400 °F
<b>Minimum temperature <math>T_{min}</math></b>	-196 °C	-320 °F

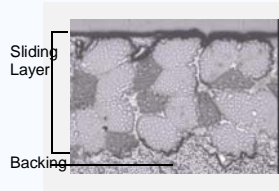

### 2.3 Special GAR-MAX<sup>®</sup> Products HSG<sup>™</sup> and MLG<sup>™</sup>

Structure	Sliding Layer Microsection	Features
<b>HSG<sup>™</sup> - High Strength GAR-MAX</b>		
<p><b>Sliding layer</b> Continuous wound PTFE and high-strength fibers encapsulated in an internally lubricated, high temperature filled epoxy resin.</p> <p><b>Backing</b> Continuous wound fiberglass encapsulated in a high temperature epoxy resin.</p>		<ul style="list-style-type: none"> <li>• High static load capacity - twice as high as standard GAR-MAX</li> <li>• Excellent shock and misalignment resistance - better than standard GAR-MAX</li> <li>• Excellent contamination resistance</li> <li>• Very good friction and wear properties</li> <li>• Good chemical resistance</li> </ul>

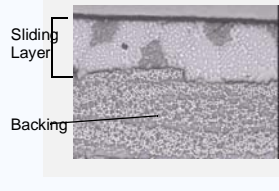
Structure	Sliding Layer Microsection	Features
<b>MLG<sup>™</sup></b>		
<p><b>Sliding layer</b> Continuous wound PTFE and high-strength fibers encapsulated in high temperature epoxy resin.</p> <p><b>Backing</b> Continuous wound fiberglass encapsulated in a high temperature epoxy resin.</p>		<ul style="list-style-type: none"> <li>• Value engineered filament wound bearing for lighter duty applications</li> <li>• High load capacity</li> <li>• Good misalignment resistance</li> <li>• Excellent shock resistance</li> <li>• Good friction and wear properties</li> <li>• Good chemical resistance</li> </ul>

Bearing Properties	HSG <sup>®</sup>		MLG <sup>™</sup>	
	SI Unit Value	ANSI Unit Value	SI Unit Value	ANSI Unit Value
<b>Ultimate Compressive strength <math>\sigma_c</math></b>	621 N/mm <sup>2</sup>	90,000 psi	414 N/mm <sup>2</sup>	60,000 psi
<b>Maximum static load <math>P_{sta,max}</math></b>	414 N/mm <sup>2</sup>	60,000 psi	207 N/mm <sup>2</sup>	30,000 psi
<b>Maximum dynamic load <math>P_{dyn,max}</math></b>	138 N/mm <sup>2</sup>	20,000 psi	138 N/mm <sup>2</sup>	20,000 psi
<b>Maximum sliding speed <math>V_{lim}</math></b>	0.13 m/s	25 fpm	0.13 m/s	25 fpm
<b>Maximum PV factor</b>	1.05 N/mm <sup>2</sup> ·m/s	30,000 psi·fpm	1.05 N/mm <sup>2</sup> ·m/s	30,000 psi·fpm
<b>Maximum temperature <math>T_{max}</math></b>	163 °C	320 °F	163 °C	320 °F
<b>Minimum temperature <math>T_{min}</math></b>	-196 °C	-320 °F	-196 °C	-320 °F

Possible applications and availability see 2.1 on Page 6

## 2.4 Hydropower Products HPM™ and HPF™

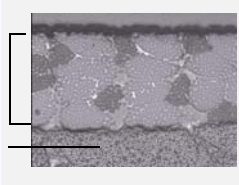
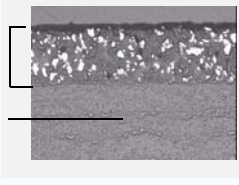
Structure	Sliding Layer Microsection	Features	Possible Applications
<b>HPM™</b>			
<p><b>Sliding layer</b> Continuous wound PTFE and high-strength fibers encapsulated in a self-lubricating, high temperature epoxy resin.</p> <p><b>Backing</b> Continuous wound fiberglass encapsulated in a high temperature epoxy resin.</p>		<ul style="list-style-type: none"> <li>• Specifically developed for hydro-power applications</li> <li>• High load capacity</li> <li>• Excellent shock and edge loading capacity</li> <li>• Low friction, superior wear rate and bearing life</li> <li>• Excellent corrosion resistance</li> <li>• Dimensional stability - low water absorption, no swelling</li> <li>• Environmentally friendly</li> </ul>	<ul style="list-style-type: none"> <li>• Servo-motor bearings</li> <li>• operating ring sliding segments</li> <li>• linkage bearings</li> <li>• wicket gate bearings</li> <li>• guide vane bearings</li> <li>• intake gate sliding segments</li> <li>• intake gate roller bearings</li> <li>• spillway gate bearings</li> <li>• trash rake bearings</li> <li>• fish screen bearings</li> <li>• trunnion bearings</li> <li>• blade bearings</li> <li>• injector bearings</li> <li>• deflector bearings</li> <li>• ball and butterfly trunnion bearings...</li> </ul>
<b>HPF™</b>			
<p><b>Sliding layer</b> Proprietary filled PTFE tape liner.</p> <p><b>Backing - Flat Material</b> Continuous woven fiber glass cloth laminate impregnated and cured with epoxy resin.</p> <p><b>Backing - Cylindrical Bearings</b> Continuous wound fiberglass encapsulated in a high temperature epoxy resin.</p>			

Bearing Properties	HPM™		HPF™		Availability
	SI Unit Value	ANSI Unit Value	SI Unit Value	ANSI Unit Value	
<b>Ultimate Compressive strength <math>\sigma_c</math></b>	345 N/mm <sup>2</sup>	50,000 psi	379 N/mm <sup>2</sup>	55,000 psi	<b>HPM, Special order</b> Cylindrical bearings to 500 mm (20 inches).
<b>Maximum static load <math>P_{sta,max}</math></b>	138 N/mm <sup>2</sup>	20,000 psi	138 N/mm <sup>2</sup>	20,000 psi	
<b>Maximum dynamic load <math>P_{dyn,max}</math></b>	138 N/mm <sup>2</sup>	20,000 psi	138 N/mm <sup>2</sup>	20,000 psi	<b>HPF, Special order</b> Cylindrical bearings, diameters up to 500 mm (20 inches); thrust bearings and wear plates.
<b>Maximum sliding speed <math>V_{lim}</math></b>	0.13 m/s	25 fpm	2.5 m/s	500 fpm	
<b>Maximum PV factor</b>	1.23 N/mm <sup>2</sup> ·m/s	35,000 psi·fpm	1.23 N/mm <sup>2</sup> ·m/s	35,000 psi·fpm	
<b>Maximum temperature <math>T_{max}</math></b>					
<b>- Cylindrical bearing material</b>	163 °C	325 °F	204 °C	400 °F	
<b>- Flat Material</b>	-	-	140 °C	284 °F	
<b>Minimum temperature <math>T_{min}</math></b>	-196 °C	-320 °F	-196 °C	-320 °F	

## 2 Material Description

### 2.5 MEGALIFE<sup>®</sup> XT Thrust Bearings

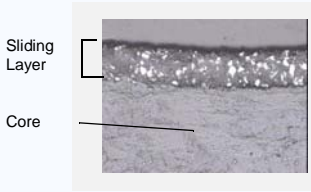
Structure	Sliding Layer Microsection	Features	Possible Applications
<b>MEGALIFE<sup>®</sup> XT</b>			
<p><b>Sliding layer</b> Proprietary filled PTFE tape liner on both sides.</p> <p><b>Core</b> Continuously woven layer of filament fiberglass encapsulated in a high temperature epoxy resin.</p>		<ul style="list-style-type: none"> <li>• High load capacity</li> <li>• Excellent shock resistance</li> <li>• Excellent misalignment resistance</li> <li>• Good surface speed capability</li> <li>• Excellent contamination resistance</li> <li>• Very good friction and wear properties</li> <li>• Good chemical resistance</li> </ul>	<ul style="list-style-type: none"> <li>• Pulley spacers</li> <li>• gear spacers</li> <li>• aerial lifts</li> <li>• fork lift masts</li> <li>• king pins</li> <li>• steering links</li> <li>• lift gates</li> <li>• cranes</li> <li>• backhoes</li> <li>• valve actuator linkages...</li> </ul>

Bearing Properties
<b>Ultimate Compressive strength</b> $\sigma_c$
<b>Maximum static load</b> $P_{sta,max}$
<b>Maximum dynamic load</b> $P_{dyn,max}$
<b>Maximum sliding speed</b> $V_{lim}$
<b>Maximum PV factor</b>
<b>Maximum temperature</b> $T_{max}$
<b>Minimum temperature</b> $T_{min}$

MEGALIFE <sup>®</sup> XT	
SI Unit Value	ANSI Unit Value
207 N/mm <sup>2</sup>	30,000 psi
138 N/mm <sup>2</sup>	20,000 psi
138 N/mm <sup>2</sup>	20,000 psi
0.50 m/s	100 fpm
1.23 N/mm <sup>2</sup> ·m/s	35,000 psi·fpm
177 °C	350 °F
-196 °C	-320 °F

Availability
<b>MEGALIFE<sup>®</sup> XT</b>
<b>Standard</b> Thrust bearings, standard sizes see pages 42-43.
<b>Special order</b> For special sizes contact GGB.

## 2.6 Performance Comparison Chart

Material	Load Carrying Capability	Shock Loading Resistance	Speed Capability	Contamination Resistance	Misalignment Resistance	Machinability
GAR-MAX	1	2	3	1	2	4
GAR-FIL	1	3	1	2	4	1
HSG	1	1	3	1	1	4
MLG	1	2	3	2	3	4
HPM	1	2	3	1	2	4
HPF, Flat Material	1	3	1	2	4	1
HPF, Cylindrical Bearing	1	3	1	2	4	1
MEGALIFE XT	2	3	2	2	3	2

Table 1: Performance Comparison Chart

Ranking	
1	Excellent
2	Good
3	Fair
4	Not Recommended

## 3 Properties

### 3.1 Physical Properties

Table 2 shows the physical properties of GGB's filament wound bearings.

#### High load capacity without lubrication

The ultimate compressive strength and maximum dynamic capacity of GGB filament wound bearings without lubrication

exceed those of most other bearing materials with lubrication.

#### Wide operating temperature range

GGB filament wound bearings can operate at much higher temperatures than lubricated bearings. This opens new applica-

tion opportunities where metallic bearings cannot function because of the limited temperature range of most greases and oils.

#### Thermal dimensional stability

GGB filament wound bearings have a thermal expansion rate similar to steel and cast iron. There is less chance of them losing their press fit or binding the shaft when

exposed to extremes of temperature. This is not the case with many other non-metallic bearings.

#### Weight savings

GGB filament wound bearings are 75% lighter than similarly sized bronze or steel bearings. This can result in a substantial

weight saving, especially with larger bearings.

Physical Properties	Units	GAR-MAX	GAR-FIL	HSG	MLG	HPM	HPF Flat Material	HPF Bearing Material	MEGA-LIFE XT
Ultimate Compressive Strength	N/mm <sup>2</sup>	414	379	621	414	345	379	379	207
	psi	60,000	55,000	90,000	60,000	50,000	55,000	55,000	30,000
Static Load Capacity	N/mm <sup>2</sup>	207	138	414	207	138	138	138	138
	psi	30,000	20,000	60,000	30,000	20,000	20,000	20,000	20,000
Maximum Dynamic Load Capacity	N/mm <sup>2</sup>	138	138	138	138	138	138	138	69
	psi	20,000	20,000	20,000	20,000	20,000	20,000	20,000	10,000
Max. Relative Surface Speed	m/s	0.13	2.50	0.13	0.13	0.13	2.50	2.50	0.50
	fpm	25	500	25	25	25	500	500	100
Maximum PV Factor	N/mm <sup>2</sup> -m/s	1.05	1.23	1.05	1.05	1.23	1.23	1.23	1.23
	psi-fpm	30,000	35,000	30,000	30,000	35,000	35,000	35,000	35,000
Max. Operating Temperature	°C	163	204	163	163	163	140	204	177
	°F	325	400	325	325	325	284	400	350
Min. Operating Temperature	°C	-196	-196	-196	-196	-196	-196	-196	-196
	°F	-320	-320	-320	-320	-320	-320	-320	-320
Thermal Expansion Rate - Hoop	10 <sup>-6</sup> /K	12.6	12.6	12.6	12.6	12.6	10.8*	12.6	12.6*
	10 <sup>-6</sup> /°F	7.0	7.0	7.0	7.0	7.0	6.0*	7.0	7.0*
Thermal Expansion Rate - Axial	10 <sup>-6</sup> /K	27.0	27.0	27.0	27.0	27.0	-	27.0	-
	10 <sup>-6</sup> /°F	15.0	15.0	15.0	15.0	15.0	-	15.0	-
Thermal Conductivity	W/mK	0.26	0.26	0.26	0.26	0.26	0.29	0.26	0.26
	BTU-in/hr-ft <sup>2</sup> -°F	1.8	1.8	1.8	1.8	1.8	2.0	1.8	1.8
Specific Gravity	-	1.87	1.96	1.87	1.87	1.87	1.9	1.96	1.85

\* lengthwise

Table 2: Physical properties of GGB filament wound bearings

### 3.2 Performance Comparison

Table 3 presents the properties information in a convenient table to help you choose the best product for your application.

Material	Max. Dynamic Capacity (<0.025 m/s (5 sfpm))		Maximum Temperature		Thermal Expansion Rate - Hoop		Specific Gravity
	N/mm <sup>2</sup>	psi	°C	°F	10 <sup>-6</sup> /K	10 <sup>-6</sup> /°F	
Cast Bronze*	41	6,000	71	160	18.0	10.0	8.80
Porous Bronze**	28	4,000	71	160	18.0	10.0	7.50
Alloyed Bronze*	69	10,000	93	200	28.8	16.0	8.10
Steel-Backed Bronze*	24	3,500	93	200	14.4	8.0	8.00
Hardened Steel*	276	40,000	93	200	12.6	7.0	7.90
Zinc Aluminum*	38	5,500	93	200	27.0	15.0	5.00
Fabric-Reinforced Phenolic*	41	6,000	93	200	36.0	20.0	1.60
Reinforced PTFE	14	2,000	260	500	99.0	55.0	2.00
GAR-MAX	138	20,000	163	325	12.6	7.0	1.87
GAR-FIL	138	20,000	204	400	12.6	7.0	1.96
HSG	138	20,000	163	325	12.6	7.0	1.87
MLG	138	20,000	163	325	12.6	7.0	1.87
HPM	138	20,000	163	325	12.6	7.0	1.87
HPF, Flat Material	138	20,000	140	284	10.8***	6.0***	1.90
HPF, Cylindrical Bearing	138	20,000	204	400	12.6	7.0	1.96
MEGALIFE XT	69	10,000	177	350	12.6***	7.0***	1.85

\*with lubrication; \*\*oil impregnated; \*\*\*lengthwise

Table 3: Comparison of various bearing materials

**Note**

Actual performance depends on the interaction of many parameters that may vary with the specific application. For example, maximum values listed for loads, speeds, and temperature cannot be used simultaneously. However, in certain applications, individual values can be exceeded. For conditions that do exceed the recommended design limits, contact our Engineering Department.

## 3.3 Chemical Resistance

GGB's filament wound bearings are resistant to a wide variety of chemicals including acids, bases, salt solutions, oils, fuels, alcohols, solvents and gases.

In fact GGB filament wound bearings offer greater chemical resistance than metallic bearings. However, GAR-FIL is resistant to the greater number of chemicals, and is used in a wide range of valves employed in the chemical processing industry as well as for fire-safe valves.

The chemical resistance of GGB's filament wound bearings to many common chemicals at 70 °F is shown in Table 4.

We recommend conducting a chemical resistance test prior to specifying a bearing that will be exposed to a chemical. An effective test (ASTM D 543) is to submerge a sample bearing in the subject chemical at the maximum anticipated operating temperature for seven days. If there is a change in the weight, dimensions, or compressive strength of the bearing, then the bearing is not resistant to the chemical.

	GAR-MAX	GAR-FIL	HSG	MLG	HPM	HPF
<b>Acids 10%</b>						
Acetic	Yes	Yes	Yes	Yes	Yes	Yes
Arsenic	No	Yes	No	No	No	Yes
Boric	Yes	Yes	Yes	Yes	Yes	Yes
Carbonic	No	No	No	No	No	No
Citric	Yes	Yes	Yes	Yes	Yes	Yes
Hydrochloric	Yes	Yes	Yes	Yes	Yes	Yes
Hydro-fluoric	No	No	No	No	No	No
Nitric	No	No	No	No	No	No
Sulfuric	Yes	Yes	Yes	Yes	Yes	Yes
<b>Bases 10%</b>						
Aluminum Hydroxide	Yes	Yes	Yes	Yes	Yes	Yes
Calcium Hydroxide	Yes	Yes	Yes	Yes	Yes	Yes
Magnesium Hydroxide	Yes	Yes	Yes	Yes	Yes	Yes
Potassium Hydroxide	Yes	Yes	Yes	Yes	Yes	Yes
Sodium Hydroxide	Yes	Yes	Yes	Yes	Yes	Yes
<b>Salts</b>						
Aluminum Chloride	Yes	Yes	Yes	Yes	Yes	Yes
Aluminum Nitrate	Yes	Yes	Yes	Yes	Yes	Yes
Aluminum Sulfate	Yes	Yes	Yes	Yes	Yes	Yes
Calcium Chloride	Yes	Yes	Yes	Yes	Yes	Yes
Ferric Chloride	Yes	Yes	Yes	Yes	Yes	Yes
Magnesium Carbonate	Yes	Yes	Yes	Yes	Yes	Yes
Magnesium Chloride	Yes	Yes	Yes	Yes	Yes	Yes
Magnesium Sulfate	Yes	Yes	Yes	Yes	Yes	Yes
Sodium Acetate	Yes	Yes	Yes	Yes	Yes	Yes
Sodium Bicarbonate	Yes	Yes	Yes	Yes	Yes	Yes
Sodium Bisulfate	Yes	Yes	Yes	Yes	Yes	Yes
Sodium Chloride	Yes	Yes	Yes	Yes	Yes	Yes
Sodium Nitrate	Yes	Yes	Yes	Yes	Yes	Yes
Zinc Sulfate	Yes	Yes	Yes	Yes	Yes	Yes
<b>Alcohols</b>						
Acetol	Yes	Yes	Yes	Yes	Yes	Yes
Allyl	No	No	No	No	No	No
Amyl	Yes	Yes	Yes	Yes	Yes	Yes
Butyl	No	No	No	No	No	No
Ethyl	Yes	Yes	Yes	Yes	Yes	Yes

	GAR-MAX	GAR-FIL	HSG	MLG	HPM	HPF
Iso Butyl	Yes	Yes	Yes	Yes	Yes	Yes
Iso Propyl	Yes	Yes	Yes	Yes	Yes	Yes
Methyl	Yes	Yes	Yes	Yes	Yes	Yes
Propyl	Yes	Yes	Yes	Yes	Yes	Yes
<b>Solvents</b>						
Acetone	Yes	Yes	Yes	Yes	Yes	Yes
Benzene	No	No	No	No	No	No
Carbon Tetrachloride	Yes	Yes	Yes	Yes	Yes	Yes
Methylene Chloride	No	No	No	No	No	No
Methyl Ethyl Ketone	Yes	Yes	Yes	Yes	Yes	Yes
Naphtha	Yes	Yes	Yes	Yes	Yes	Yes
Toluol	Yes	Yes	Yes	Yes	Yes	Yes
Trichlorethane	No	Yes	No	No	No	Yes
<b>Oils</b>						
Cottonseed	Yes	Yes	Yes	Yes	Yes	Yes
Crude Oil	Yes	Yes	Yes	Yes	Yes	Yes
Hydraulic Fluids	Yes	Yes	Yes	Yes	Yes	Yes
Linseed Oil	Yes	Yes	Yes	Yes	Yes	Yes
Motor Oil	Yes	Yes	Yes	Yes	Yes	Yes
Transmission Fluids	Yes	Yes	Yes	Yes	Yes	Yes
<b>Fuels</b>						
Diesel	Yes	Yes	Yes	Yes	Yes	Yes
Gasoline	Yes	Yes	Yes	Yes	Yes	Yes
Jet Fuel	Yes	Yes	Yes	Yes	Yes	Yes
Kerosene	Yes	Yes	Yes	Yes	Yes	Yes
<b>Gases</b>						
Acetylene Bromine	No	No	No	No	No	No
Butane	Yes	Yes	Yes	Yes	Yes	Yes
Carbon Dioxide	Yes	Yes	Yes	Yes	Yes	Yes
Chlorine	No	Yes	No	No	No	Yes
Ethers	Yes	Yes	Yes	Yes	Yes	Yes
Fluorine	No	No	No	No	No	No
Hydrogen	Yes	Yes	Yes	Yes	Yes	Yes
Natural Gas	Yes	Yes	Yes	Yes	Yes	Yes
Nitrogen	Yes	Yes	Yes	Yes	Yes	Yes
Ozone	Yes	Yes	Yes	Yes	Yes	Yes
Propane	Yes	Yes	Yes	Yes	Yes	Yes
Sulfur Dioxide	Yes	Yes	Yes	Yes	Yes	Yes
<b>Miscellaneous</b>						
Anhydrous Ammonia	No	No	No	No	No	No
Detergents	Yes	Yes	Yes	Yes	Yes	Yes
Ethylene Glycol	Yes	Yes	Yes	Yes	Yes	Yes
Formaldehyde	Yes	Yes	Yes	Yes	Yes	Yes
Freon	Yes	Yes	Yes	Yes	Yes	Yes
Hydrogen Peroxide	No	No	No	No	No	No
Lime	Yes	Yes	Yes	Yes	Yes	Yes
Water	Yes	Yes	Yes	Yes	Yes	Yes

Table 4: Chemical resistance



## 4 Data for Designers

### 4.1 Wear Rate

In the high load applications anticipated for filament wound bearings, radial displacement will result from a combination of many variables. These include adhesive wear, abrasion, deformation due to misalignment of the shaft, high interface temperatures, ingress of dirt, fluid contamination and mating surface conditions. With design pressures of less than 69 N/mm<sup>2</sup>

[10,000 psi], millions of cycles can be achieved with GAR-MAX, HSG, GAR-FIL, HPM and HPF bearings.

Fig. 3 and Fig. 4 show the rate of wear measured in continuous cycle testing for a GAR-MAX and GAR-FIL bearing operating at 103 N/mm<sup>2</sup> [15,000 psi].

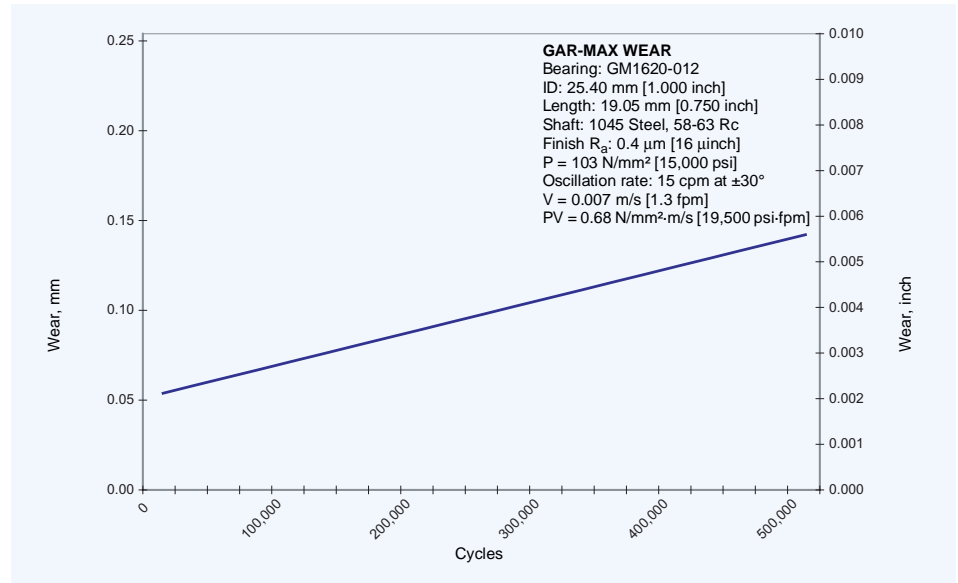

Fig. 3: Wear rate for GAR-MAX

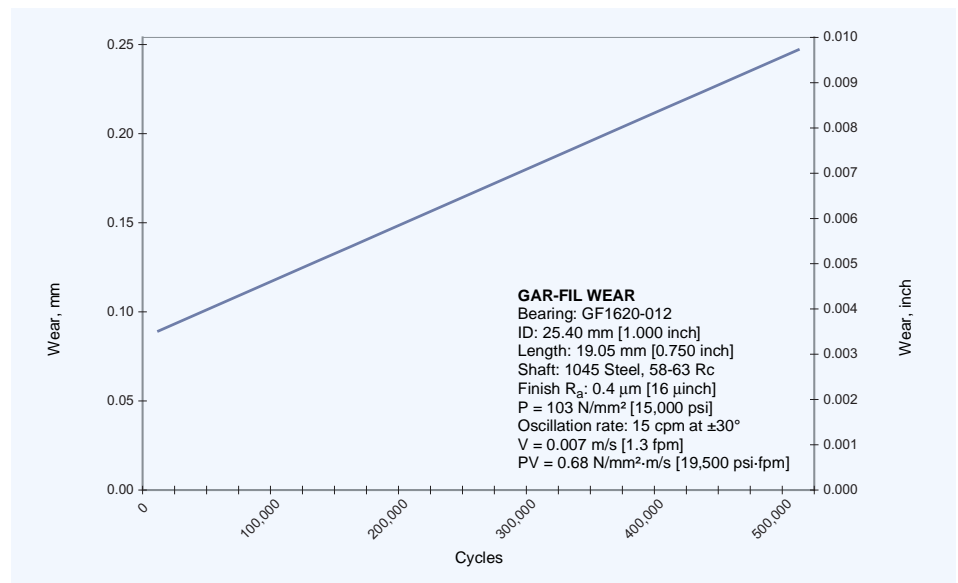

Fig. 4: Wear rate for GAR-FIL

## 4.2 Frictional Properties

The prime factors affecting the friction of filament wound bearings are pressure, velocity, temperature and mating surface conditions. Generally, the pressure is the most influential.

Fig. 5 shows how friction changes at various pressures. This information can be used to estimate the torque required to initiate motion in GGB filament wound bearings:

$$(4.2.1) \quad \text{Torque} = \frac{\mu \cdot F \cdot D_i}{2000} \quad [\text{N}\cdot\text{m}]$$

or

$$(4.2.2) \quad \text{Torque} = \frac{\mu \cdot F \cdot D_i}{2} \quad [\text{lbs}\cdot\text{in}]$$

Where	
$\mu$	coefficient of friction
$F$	Applied load [Newtons] or [pounds]
$D_i$	Bearing nominal ID, [mm] or [inches]

This equation can be used to determine frictional losses that a bearing contributes to a system.

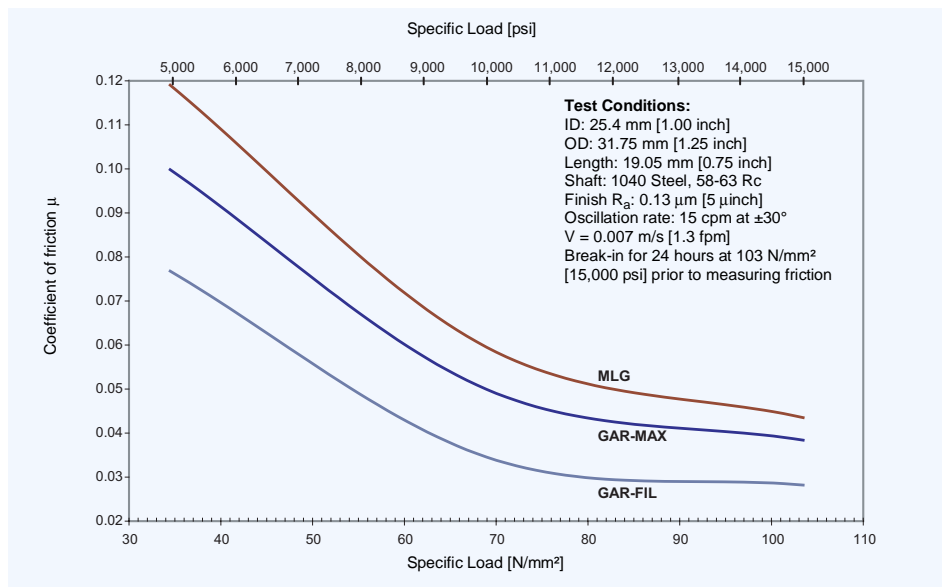

Fig. 5: Coefficient of friction vs specific load

With frequent starts and stops, the static coefficient of friction is approximately equal to or slightly less than the dynamic coefficient of friction as measured in laboratory testing. After progressively longer periods of sitting idle or dwell under load (e.g., of hours or days), the static coefficient of friction of the first movement has been mea-

sured to be up to 200% higher, particularly before bedding-in. This phenomenon must be considered when designing long dwell period applications. Extremely low torque applications should be monitored or specifically tested for friction when prime mover torque requirements must be determined.

### 4.3 Operating Temperature

Operating temperature is an important consideration when specifying bearing materials since temperature will have a direct affect on bearing load capacity and wear resistance. GGB filament wound bearings consist of a rugged outer shell of filament wound fiberglass encapsulated in high temperature epoxy. This combination of materials permit GGB filament wound bearings to operate at higher temperatures than most other conventional plain bear-

ings as indicated in Table 3. At elevated temperatures GGB filament wound bearings have reduced load carrying capabilities due to the softening of the self-lubricating surfaces; however, GAR-MAX, HSG, MLG and HPM are not influenced by temperature to the same degree as GAR-FIL and HPF. GAR-FIL bearings have been used in low temperature (cryogenic) applications.

### 4.4 Load Capacity

The maximum unit load which can be supported by filament wound bearings will depend upon the type of loading. It will be highest under steady loads, whereas, dynamic loads or oscillating motion, which produce fatigue stresses in the bearing, will result in a reduction of load capacity. The maximum unit loads specified in Table 2 assume good alignment between the bearing and mating surface and running clearances listed in the standard product tables on pages 32 through 41.

The maximum static and dynamic loads given in Table 2 are based on bearings having a wall thickness of 2.5 mm [0.100 inch] or greater. Thin-walled bearings, those with a wall thickness between 1.5 mm [0.060 inch] and 2.5 mm [0.100 inch] have a reduced load capacity because of the reduced number of filament wound fiberglass crossovers that constitute the backing material. Wall thicknesses greater than 6.35 mm [0.250 inch] do not increase load capacity.

Many applications for GAR-MAX and HSG bearings involve applied loads plus the presence of shock and impulse loading

along with additional loads due to structural bending. As an example, hydraulic cylinder pivots or clevis joints used in front end loaders, graders, and other types of off-highway vehicles require the consideration of misalignment and G-impact force. Experience gained in the application of GAR-MAX and HSG bearings on this type of equipment has led us to recommend the maximum specific load (pressures) shown in Table 5. Greater specific loads have shown surface distress in operation since the cumulative influence of misalignment and shock will increase the actual specific load.

The bearing length can also influence the distribution of load along the length of the bearing. A bearing that is heavily loaded and having a relatively long length will, due to shaft deflection, have disproportionately high unit loading at each end. For this reason, we do not recommend length-to-diameter ratios that are greater than 2.0. Conversely, very short bearings, those with length-to-diameter ratios less than 0.25 are not recommended because of potential bearing retention problems.

Application	Design Specific Load*		Impact [G]
	N/mm <sup>2</sup>	psi	
Dozer Yoke	34	5,000	3
Excavators	34	5,000	3
Back Hoes	34	5,000	3
Loader Linkage	34	5,000	3
Rollers	48	7,000	2
Bogie Wheel Pivots	48	7,000	2
Track Frame Pivots	48	7,000	2
Steer Cylinders	69	10,000	1
Control Linkage	69	10,000	1
Dump/Swing Cylinders	69	10,000	1

\* Includes hydraulic check valve pressure but does not include impact, misalignment or vehicle driving force

Table 5: Specific application impact loading factors

## 4.5 Surface Velocity

GGB's filament wound bearings can operate over a wide range of operating velocities as shown in Table 2.

**GAR-FIL and HPF** bearings can operate without lubrication at speeds up to 2.5 m/s [500 fpm] with a maximum PV value to 0.3 N/mm<sup>2</sup>·m/s [9,000 psi·fpm]. This performance capability is due to the proprietary filled-PTFE liner. Since surface velocity influences the amount of heat generated in a plain bearing, additional clearance may be required at higher operating speeds. With GAR-FIL and HPF bearings, when operating over 0.25 m/s [50 fpm], additional clearances are required to

accommodate for thermal expansion due to the heat generated.

**GAR-MAX, HSG, MLG and HPM** bearings, which have a maximum speed limit of 0.13 m/s [25 fpm], are more suitable for high-load and low-speed applications. Since most GAR-MAX, HSG, MLG and HPM bearings are designed to operate at less than 0.05 m/s [10 fpm], additional clearances are normally not required.

**MEGALIFE XP** bearings are limited to 0.10 m/s [20 fpm].

**MEGALIFE XT** thrust washers are limited to 0.50 m/s [100 fpm].

## 4.6 PV Factor

The PV factor, which is the product of specific load (pressure) times surface velocity, is used as a guide in determining the useful life of plain bearings and is also an indication of heat generated within the bearing contact zone. The maximum PV factors listed in Table 2 are based on high-load and low-speed applications. The calculated unit load P, relative surface velocity V and operating temperature must be used along with the PV factor when selecting a

bearing material for a given application. These values are then compared against published maximum recommended values for load, speed, temperature and PV for the bearing material. For an application to be successful, each of the application values must not exceed the published maximum recommended values. To complete the bearing analysis, bearing life should be estimated using the method given in section 5.5.

### 4.7 Operating Clearances

Proper running clearance is a critical factor in bearing performance. In low speed oscillating pivot applications, the minimum possible recommended clearance can be as small as 0.013 mm [0.0005 inch] for filament wound bearings. The shaft or pin will fit nearly line-to-line during the assembly process. However, since little or no heat is generated during very slow oscillating operation, additional clearance is not required. For more dynamic applications involving continuous rotation at higher speeds or elevated ambient temperatures, minimum clearances may be as high as 0.005 mm/mm [0.005 inch/inch] of diameter.

GAR-MAX, HSG, MLG, HPM and bearings cannot be sized or machined on their ID due to the liner composition. However, GAR-FIL and HPF bearings can be sized or machined for close tolerance control. Standard GAR-FIL and HPF bearings are supplied with a 0.38 mm [0.015 inch] thick proprietary filled-PTFE tape liner that can be bored at assembly if necessary. GAR-FIL and HPF bearings can also be furnished with a thicker liner that allows for a greater amount of boring. For further information, contact GGB.

### 4.8 Dimensional Considerations

Before designing a special GGB filament wound bearing, there are several important considerations to keep in mind:

- **Wall Thickness**

Bearings with wall thicknesses less than 2.5 mm [0.100 inch] should be avoided since thin-walled bearings have reduced load capacity, approximately 50% less than our rated load capacity for GGB filament wound bearings. The minimum recommended wall thickness is 1.5 mm [0.060 inch]. Wall thicknesses greater than 6.35 mm [0.250 inch] do not increase load capacity.

- **Clearance**

As noted previously, the minimum running clearance applies only to low speed applications operating at ambient temperatures. For GAR-FIL and HPF bearings operating at surface speeds greater than 0.25 m/s [50 fpm] or at elevated temperatures, additional clearance may be required.

- **Bearing Length**

In designing bearings, the shaft diameter is usually determined by the need for physical stability or stiffness; therefore, only the bearing length must be determined based upon operating pressure and required life. A short bearing should be limited to a length-to-diameter ratio of 0.25 as a minimum to insure sufficient retention in the housing. A long bearing is not recommended because of potential shaft deflection and misalignment problems as described in Section 5.7. A long heavily loaded bearing will have disproportionately high specific loading at each end due to shaft deflection. For this reason, we do not recommend length-to-diameter ratios greater than 2.0.

## 4.9 Shaft Material and Surface Finish

Since the shaft is considered to be an equal part of the bearing assembly, the importance of proper shaft specification cannot be overemphasized. Most steel alloys are acceptable as shaft materials. Hardened steel shafts offer better performance in high load applications or in the presence of abrasive contaminants by providing greater protection for the mating surface. When bearing operating pressures exceed a value of about 14 N/mm<sup>2</sup> [2,000 psi], minimum shaft hardness should be at least Brinell 480 HB [Rockwell C50]. Fully hardened shafts are usually not necessary. GGB filament wound bearings offer good embeddability in the presence of contaminants; however, we strongly recommend the use of seals. Hardened stainless steel or hard chrome

plating is recommended when corrosion resistance is required.

Equally important as material selection is shaft surface finish. A surface finish between 0.15 to 0.40 micrometers [6 to 16 microinches] will insure the most effective bearing performance by assuring maximum bearing wear resistance and lowest coefficient of friction. Rougher surface finishes can be used but there will be a reduction in bearing life. This is due to the rough shaft abrading the relatively soft polymer liner of the bearings.

We recommend that the ends of the shaft have chamfers or rounded edges to facilitate assembly and minimize the chance of scoring the bearing.

## 4.10 Housing Material

The running clearances given in section 7 for standard GGB filament wound bearings are based upon installation in rigid steel or cast iron housings at normal ambient temperature. If the housing is made from non-ferrous alloys, such as aluminum, and will be subjected to elevated operating temperatures, there will be a potential for reduced bearing retention due to the thermal expansion of the housing. In applications

where non-ferrous alloy housings are to be used at elevated temperatures, the interference between the bearing and housing bore may have to be increased to assure adequate retention of the bearing in the housing. To prevent shaft interference at assembly, the shaft diameter must be equally reduced to compensate for the additional interference fit. For further information contact GGB.

## 4.11 Lubrication

GGB filament wound bearings are recommended to be used dry. However, grease can be used to protect and/or to purge the bearing zone of corrosion or contaminants. In applications where high cyclic vibrations are present, hydrostatic erosion of liner fibers by the grease may occur over long periods of time. This should be monitored to assure liner integrity over the operating life of the equipment.

**GAR-FIL and HPF** bearings can be used when submerged in oil or other lubricating liquids. Liquidous lubricants will reduce the coefficient of friction and bearing wear. However, the lubricant must be constantly maintained and kept free of abrasive contaminants. Grease is not recommended for GAR-FIL and HPF bearings.

**HPM and HPF** bearings are specifically designed for hydropower applications where they can be used both dry and submerged in water. We recommend that hardened stainless steel shafting, such as 440 stainless steel, be used to minimize the chance of shaft corrosion.

**MEGALIFE XT** washers and wear plates are typically used dry but can also be used in greased applications.

Liquid lubricants and greases attract contaminating particles that may migrate into the bearing. To minimize bearing contamination, the use of seals or wipers is highly recommended.

## 5 Performance

The following section describes how to estimate bearing life for GGB filament wound bearings. This method involves calculation of the PV factor which is then further modified by application factors for unit

loading, bearing length, operating temperature, mating surface and bearing diameter. If you need additional assistance in estimating bearing life, feel free to contact GGB.

### 5.1 Design Factors

The main parameters when determining the size or estimating the service life for a GGB filament wound bearing are:

- Specific load limit,  $P_{lim}$
- PV factor
- Length-to-diameter ratio
- Mating surface finish
- Mating surface material
- Temperature
- Other environmental factors, e.g., housing design, dirt, lubrication

### 5.2 Specific Load, P

The formula for calculating the specific load, P, for bearings is:

**Bearing**

(5.2.1) [N/mm<sup>2</sup>] or [psi]

$$P = \frac{F}{D_i \cdot B}$$

Where	
$P$	Specific load, [N/mm <sup>2</sup> ] or [psi]
$F$	Applied load [Newtons] or [pounds]
$D_i$	Nominal ID, [mm] or [inches]
$B$	Bearing length, [mm] or [inches]

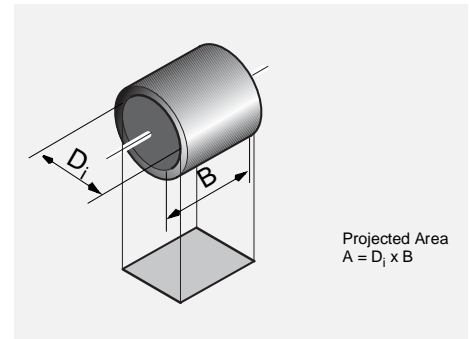

Fig. 6: Projected area for bearing

### 5.3 Sliding Speed, $V$

The formulae for calculating sliding speed are:

#### Bearings

$$(5.3.1) \quad V = \frac{D_i \cdot \pi \cdot N}{60 \cdot 10^3} \quad [\text{m/s}]$$

or

$$(5.3.2) \quad V = \frac{D_i \cdot \pi \cdot N}{12} \quad [\text{fpm}]$$

#### Where

$V$  Sliding speed, [m/s] or [fpm]

$N$  Rotational speed, [1/min]

#### For oscillating applications

$$(5.3.3) \quad N = \frac{4 \cdot \varphi \cdot N_{osc}}{360} \quad [1/\text{min}]$$

#### Where

$N_{osc}$  Oscillating movement frequency, [1/min]

$\varphi$  Angular displacement, [°]

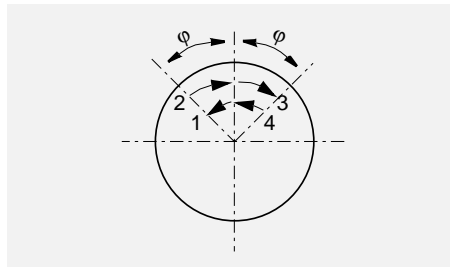

Fig. 7: Oscillating cycle,  $\varphi$

### 5.4 PV Factor

The useful life of a GGB filament wound bearing is governed by the PV factor, the product of the specific load,  $P$ , and the sliding speed,  $V$ , as defined in 5.2 and 5.3 respectively.

The formula for calculating PV is:

$$(5.4.1) \quad PV = P \cdot V \quad [\text{N/mm}^2 \cdot \text{m/s}] \text{ or } [\text{psi} \cdot \text{fpm}]$$



## 5.5 Estimating Bearing Life

### Cyclic Bearing Life, $L_Q$

The cyclic bearing life of a GGB filament wound sleeve bearing is estimated by using the following formulae:

#### GAR-MAX and HSG

(5.5.1) [cycles]

$$L_Q = \frac{Q_{GM}}{PV} \cdot a_E \cdot a_T \cdot a_M \cdot a_S \cdot a_B$$

#### MLG

(5.5.2) [cycles]

$$L_Q = \frac{Q_{MLG}}{PV} \cdot a_E \cdot a_T \cdot a_M \cdot a_S \cdot a_B$$

#### GAR-FIL

(5.5.3) [cycles]

$$L_Q = \frac{Q_{GF}}{PV} \cdot a_E \cdot a_T \cdot a_M \cdot a_S \cdot a_B$$

Where	
$L_Q$	Estimated bearing life, [cycles]
$Q_{GF}$	GAR-FIL cyclic life factor, see Table 6
$Q_{GM}$	GAR-MAX and HSG cyclic life factor, see Table 6
$Q_{MLG}$	MLG cyclic life factor, see Table 6
$PV$	PV factor, P·V, [N/mm <sup>2</sup> ·m/s] or [psi·fpm]
$a_E$	High load factor
$a_T$	Temperature factor
$a_M$	Mating surface factor
$a_S$	Surface finish factor
$a_B$	Bearing size factor

Product	Factor	Cyclic Life Factors	
		N/mm <sup>2</sup> ·m/s	psi·fpm
GAR-MAX	$Q_{GM}$	$3.8 \cdot 10^6$	$11.0 \cdot 10^{10}$
HSG	$Q_{GM}$	$3.8 \cdot 10^6$	$11.0 \cdot 10^{10}$
MLG	$Q_{MLG}$	$1.4 \cdot 10^6$	$4.0 \cdot 10^{10}$
GAR-FIL	$Q_{GF}$	$2.4 \cdot 10^6$	$7.0 \cdot 10^{10}$

Table 6: Cyclic Life Factors

### High Load Factor, $a_E$

The high load factor considers both the effect of the specific load and the bearing's B/D<sub>i</sub> (length-to-diameter) ratio. Table 7 shows the specific load limit, P<sub>lim</sub>, for various operating conditions. Fig. 8 shows a graph of the length factor, a<sub>B/D<sub>i</sub></sub>, versus

B/D<sub>i</sub>. Once the values for P<sub>lim</sub> and a<sub>B/D<sub>i</sub></sub> are selected, the high load factor, a<sub>E</sub>, can be calculated as shown. If the calculated a<sub>E</sub> value is negative, then the designer must consider a larger bearing in order to reduce the specific load, P.

(5.5.4)

$$a_E = \left( \frac{P_{lim} - P}{P_{lim}} \right)^{a_{B/D_i}}$$

Where	
$P_{lim}$	Specific load limit, see Table 7, [N/mm <sup>2</sup> ] or [psi]
$P$	Specific load, [N/mm <sup>2</sup> ] or [psi]
$a_{B/D_i}$	B/D <sub>i</sub> factor taken from Fig. 8

Type of loading	Units	Specific Load Limit $P_{lim}$	
		GAR-MAX, HSG, MLG	GAR-FIL
Steady unidirectional loads relative to the bearing surface with rotation in one direction only.	N/mm <sup>2</sup>	138	138
	psi	20,000	20,000
Steady unidirectional loads with oscillating motion.	N/mm <sup>2</sup>	138	138
	psi	20,000	20,000
Dynamic loads, alternating or fluctuating, with rotating or oscillating motion.	N/mm <sup>2</sup>	103	103
	psi	15,000	15,000
Rotating load relative to bearing surface, e.g., fully rotational bearing on stationary shaft.	N/mm <sup>2</sup>	55 (<0.025 m/s)	14 (<0.125 m/s)
	psi	8,000 (<5 fpm)	2,000 (<25 fpm)

Table 7: Specific load limit,  $P_{lim}$

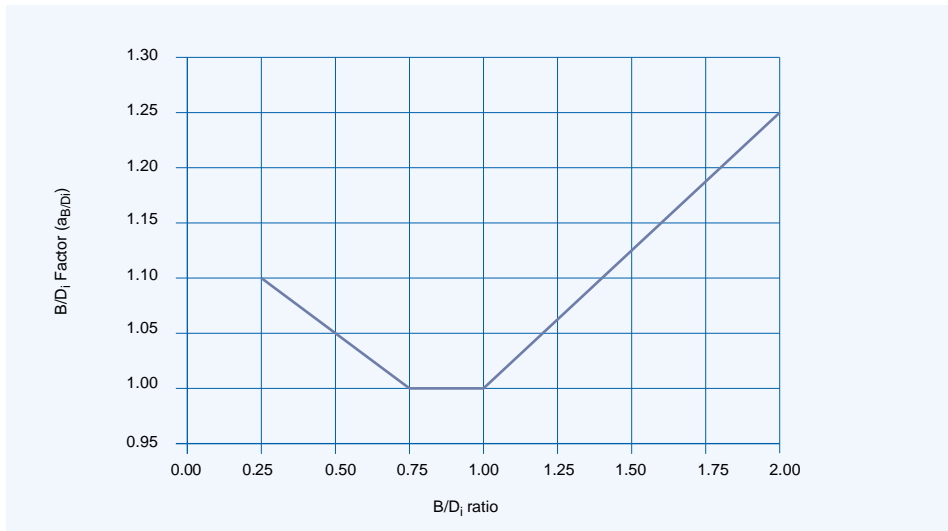

Fig. 8: B/D<sub>1</sub> factor  $a_{B/D_1}$

Type of Load

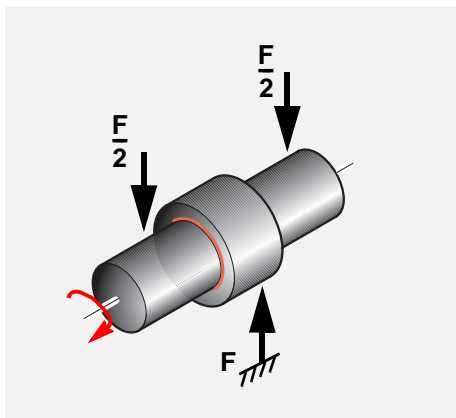

Fig. 9: Steady load, Bush Stationary, Shaft rotating

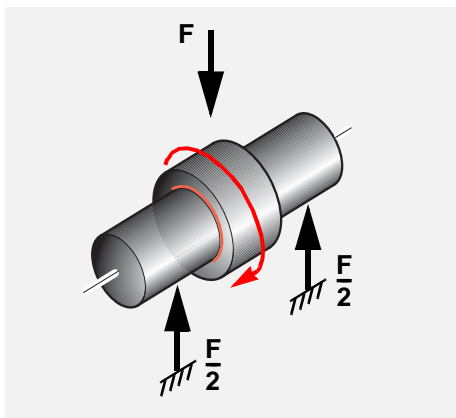

Fig. 10: Rotating load, shaft stationary, bush rotating

## Temperature Factor - $a_T$

The effect of environmental temperature on the bearing life is given in Fig. 11. Elevated temperatures tend to soften the non-metallic bearing surface resulting in reduced wear resistance and load capacity. Since the bearing surface of GAR-FIL consists of a proprietary filled PTFE mate-

rial, bearing life will be influenced by temperature to a greater degree than GAR-MAX, HSG and MLG. When the operating temperature approaches the top limit of 205 °C [400 °F] for GAR-FIL or 163 °C [325 °F] for GAR-MAX, HSG and MLG, contact GGB.

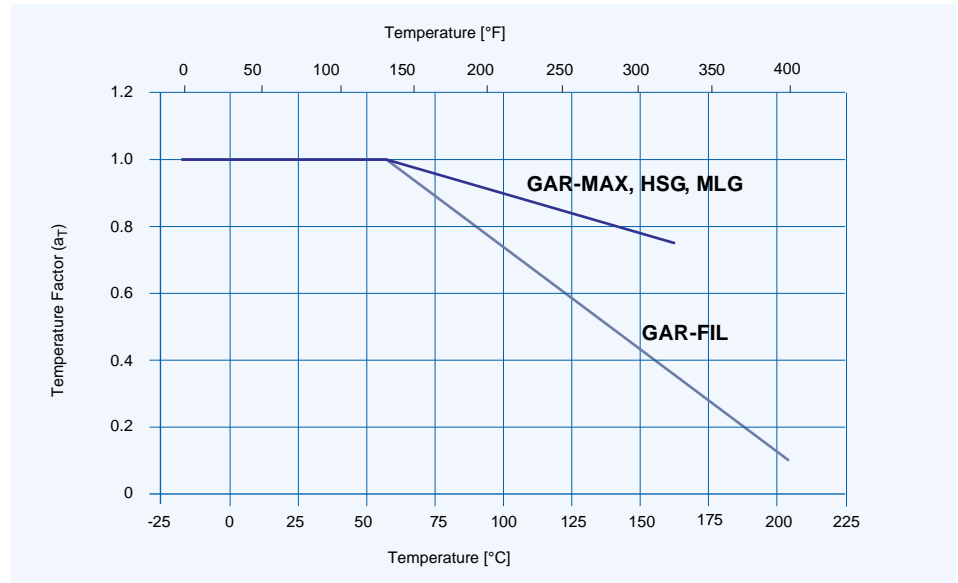

Fig. 11: Temperature factor  $a_T$

## Mating Material Factor - $a_M$

The effect of shaft material on self-lubricating bearing life is reflected in Table 8 which lists the mating surface material factors,  $a_M$ , for many commonly used shaft materi-

als and shaft finishes. When plated shafting is to be used, designers should specify that the plating possesses adequate strength and adhesion.

Material	Mating Surface Factor $a_M$
<b>Steels</b>	
Case-hardened Steel	1
Mild Steel	1
Nitrided Steel	1
Hardened Stainless Steel	1.2
<b>Non-Ferrous Metals</b>	
Bronze & Copper Based Alloys	0.1-0.4
Hard Anodized Aluminium, 0.025 mm (0.001 inch) thick	1.5
<b>Plated Steel, 0.013 mm (0.0005 inch) minimum plating thickness</b>	
Hard Chrome (polished after plating)	1.2
Tin Nickel	1.2
Tungsten Carbide Flame Plated	1.5
Zinc (Galvanized)	0.2

Table 8: Mating Surface Factor  $a_M$

### Mating Surface Factor - $a_S$

Shaft surface finish is a very important consideration when estimating bearing life. Fig. 12 shows a relationship of the mating surface factor,  $a_S$ , with respect to surface finish in micrometers [microinches]. To maximize bearing life, a surface finish of 0.15 to 0.40  $\mu\text{m}$  [6 to 16  $\mu\text{inch}$ ]  $R_a$  is recommended. Rougher surface finishes will result in reduced bearing life because they will tend to rake through the soft polymer

liners and accelerate wear. On the other hand, very fine finishes do not permit the adequate transfer of the self-lubricating material onto the shaft surface and will also tend to reduce bearing life in dry applications. If rougher finishes are to be considered, testing should be conducted based on dynamics and operating pressures for the application.

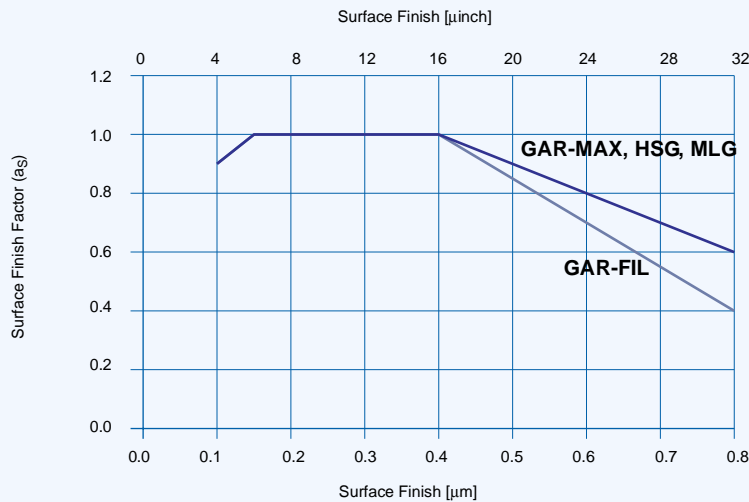

Fig. 12: Mating Surface Factor  $a_S$

### Bearing Size Factor - $a_B$

As the bearing size increases there is a relatively smaller angular contact area after initial bedding-in occurs. This reduction in contact area has the effect of

increasing the actual unit loading and consequently will result in reducing bearing life. The bearing size factor  $a_B$  versus shaft diameter is plotted in Fig. 14.

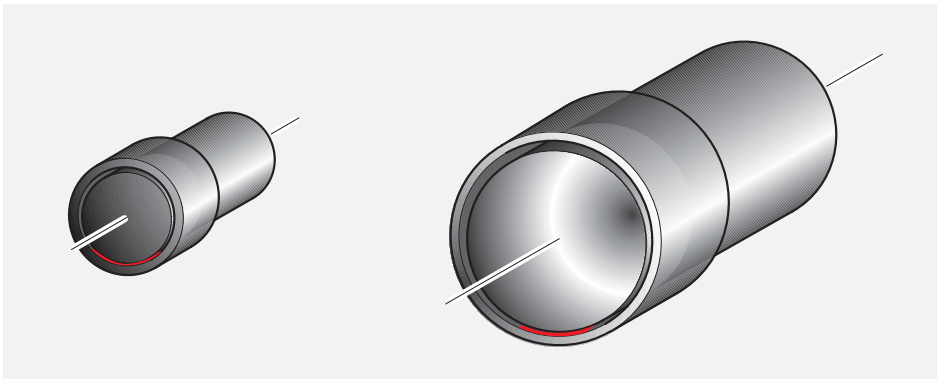

Fig. 13: Contact area between bearing and shaft.

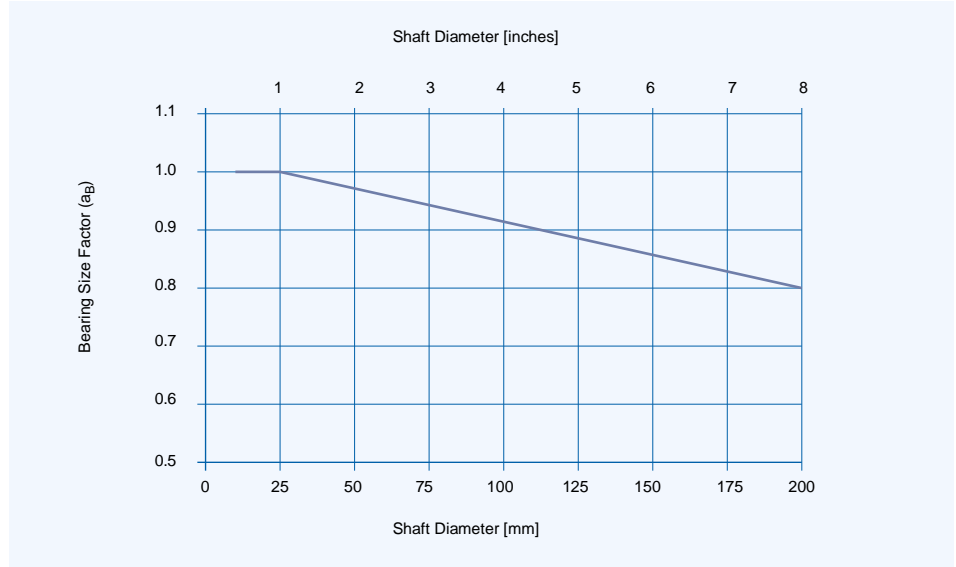

Fig. 14: Bearing Size Factor  $a_B$

## 5.6 Worked Examples

### GAR-MAX®

Given				
Load Details	Steady Load	Inside Diameter, $D_i$	2.25 inch	$\frac{B}{D_i} = \frac{2.00}{2.25} = 0.89$
	Shaft oscillating	Length, B	2.00 inch	
Shaft	Hardened Steel, $R_a = 20 \mu\text{inch}$	Bearing Load, F	60,000 pounds	
Environment	Ambient Temperature = 72 °F	Frequency, $N_{osc}$	15 cycles/min.	
		Amplitude, $\phi$	20°	

#### Calculation Constants and Application Factors

Specific Load Limit, P	20,000 psi	(Table 7, Page 25)
B/ $D_i$ Factor, $a_{B/D_i}$	1.0	(Fig. 8, Page 25)
Temperature Factor, $a_T$	1.0	(Fig. 11, Page 26)
Mating Material Factor, $a_M$	1.0	(Table 8, Page 26)
Mating Surface Factor, $a_S$	0.9	(Fig. 12, Page 27)
Bearing Size Factor, $a_B$	0.96	(Fig. 14, Page 28)
Cyclic Life Factor, $Q_{GM}$	$11 \cdot 10^{10}$ psi-fpm	(Table 6, Page 24)

Calculation	Reference	Value
Specific Load, P [N/mm <sup>2</sup> ] or [psi]	(5.2.1), Page 22	$P = \frac{F}{D_i \cdot B} = \frac{60,000}{2.25 \cdot 2.00} = 13,333 \text{ psi}$
Sliding Speed, V [m/s] or [fpm]	(5.3.1), Page 23	$V = \frac{D_i \cdot \pi \cdot N}{12} = \frac{2.25 \cdot \pi \cdot 3.333}{12} = 1.96 \text{ fpm}$ ( $N = \frac{4 \cdot \phi \cdot N_{osc}}{360} = 3.333 \text{ rpm}$ )
PV Factor, PV [N/mm <sup>2</sup> ·m/s] or [psi-fpm]	(5.4.1), Page 23	$PV = P \cdot V = 13,333 \cdot 1.96 = 26,133 \text{ psi} \cdot \text{fpm}$
High Load Factor, $a_E$	(5.5.4), Page 24	$a_E = \left( \frac{P_{lim} - P}{P_{lim}} \right)^{a_{B/D_i}} = \left( \frac{20,000 - 13,333}{20,000} \right)^{1.0} = 0.333$
Life, $L_Q$ [cycles]	(5.5.1), Page 24	$L_Q = \frac{Q_{GM}}{PV} \cdot a_E \cdot a_T \cdot a_M \cdot a_S \cdot a_B = \frac{11 \cdot 10^{10}}{26,133} \cdot 0.333 \cdot 1.0 \cdot 1.0 \cdot 0.9 \cdot 0.96 = 1.2 \cdot 10^6 \text{ cycles}$

### GAR-FIL®

Given				
Load Details	Steady Load	Inside Diameter, $D_i$	40 mm	$\frac{B}{D_i} = \frac{40}{40} = 0.5$
	Shaft oscillating	Length, B	20 mm	
Shaft	Hardened Steel, $R_a = 0.2 \mu\text{m}$	Bearing Load, F	50,000 Newtons	
Environment	Ambient Temperature = 75 °C	Frequency, $N_{osc}$	10 cycles/min.	
		Amplitude, $\phi$	30°	

#### Calculation Constants and Application Factors

Specific Load Limit, P	138 N/mm <sup>2</sup>	(Table 7, Page 25)
B/ $D_i$ Factor, $a_{B/D_i}$	1.05	(Fig. 8, Page 25)
Temperature Factor, $a_T$	0.9	(Fig. 11, Page 26)
Mating Material Factor, $a_M$	1.2	(Table 8, Page 26)
Mating Surface Factor, $a_S$	1.0	(Fig. 12, Page 27)
Bearing Size Factor, $a_B$	0.98	(Fig. 14, Page 28)
Cyclic Life Factor, $Q_{GF}$	$2.4 \cdot 10^6$ N/mm <sup>2</sup> ·m/s	(Table 6, Page 24)

Calculation	Reference	Value
Specific Load, P [N/mm <sup>2</sup> ] or [psi]	(5.2.1), Page 22	$P = \frac{F}{D_i \cdot B} = \frac{50,000}{40 \cdot 20} = 62.5 \text{ N/mm}^2$
Sliding Speed, V [m/s] or [fpm]	(5.3.1), Page 23	$V = \frac{D_i \cdot \pi \cdot N}{60 \cdot 10^3} = \frac{40 \cdot \pi \cdot 3.333}{60 \cdot 10^3} = 0.007 \text{ m/s}$ ( $N = \frac{4 \cdot \phi \cdot N_{osc}}{360} = 3.333 \text{ rpm}$ )
PV Factor, PV [N/mm <sup>2</sup> ·m/s] or [psi-fpm]	(5.4.1), Page 23	$PV = P \cdot V = 62.5 \cdot 0.007 = 0.438 \text{ N/mm}^2 \cdot \text{m/s}$
High Load Factor, $a_E$	(5.5.4), Page 24	$a_E = \left( \frac{P_{lim} - P}{P_{lim}} \right)^{a_{B/D_i}} = \left( \frac{138 - 62.5}{138} \right)^{1.05} = 0.531$
Life, $L_Q$ [cycles]	(5.5.1), Page 24	$L_Q = \frac{Q_{GM}}{PV} \cdot a_E \cdot a_T \cdot a_M \cdot a_S \cdot a_B = \frac{2.4 \cdot 10^6}{0.438} \cdot 0.531 \cdot 0.9 \cdot 1.2 \cdot 1.0 \cdot 0.98 = 3.1 \cdot 10^6 \text{ cycles}$

## HSG™

Given				
Load Details	Dynamic Loads	Inside Diameter, $D_i$	6.00 inch	$\frac{B}{D_i} = \frac{4.00}{6.00} = 0.67$
	Shaft oscillating	Length, B	4.00 inch	
Shaft	Hardened Steel, $R_a = 16 \mu\text{inch}$	Bearing Load, F	180,000 pounds	
Environment	Ambient Temperature = 72 °F	Frequency, $N_{osc}$	6 cycles/min.	
		Amplitude, $\phi$	15°	

### Calculation Constants and Application Factors

Specific Load Limit, P	15,000 psi	(Table 7, Page 25)
B/ $D_i$ Factor, $a_{B/D_i}$	1.02	(Fig. 8, Page 25)
Temperature Factor, $a_T$	1.0	(Fig. 11, Page 26)
Mating Material Factor, $a_M$	1.0	(Table 8, Page 26)
Mating Surface Factor, $a_S$	1.0	(Fig. 12, Page 27)
Bearing Size Factor, $a_B$	0.85	(Fig. 14, Page 28)
Cyclic Life Factor, $Q_{GM}$	$11 \cdot 10^{10}$ psi-fpm	(Table 6, Page 24)

Calculation	Reference	Value
Specific Load, P [N/mm <sup>2</sup> ] or [psi]	(5.2.1), Page 22	$P = \frac{F}{D_i \cdot B} = \frac{180,000}{6 \cdot 4} = 7,500 \text{ psi}$
Sliding Speed, V [m/s] or [fpm]	(5.3.1), Page 23	$V = \frac{D_i \cdot \pi \cdot N}{12} = \frac{6 \cdot \pi \cdot 1}{12} = 1.571 \text{ fpm}$ <span style="float: right;"><math>(N = \frac{4 \cdot \phi \cdot N_{osc}}{360} = 1 \text{ rpm})</math></span>
PV Factor, PV [N/mm <sup>2</sup> ·m/s] or [psi·fpm]	(5.4.1), Page 23	$PV = P \cdot V = 7,500 \cdot 1.571 = 11,783 \text{ psi} \cdot \text{fpm}$
High Load Factor, $a_E$	(5.5.4), Page 24	$a_E = \left( \frac{P_{lim} - P}{P_{lim}} \right)^{a_{B/D_i}} = \left( \frac{15,000 - 7,500}{15,000} \right)^{1.02} = 0.493$
Life, $L_O$ [cycles]	(5.5.1), Page 24	$L_O = \frac{Q_{GM}}{PV} \cdot a_E \cdot a_T \cdot a_M \cdot a_S \cdot a_B = \frac{11 \cdot 10^{10}}{11,783} \cdot 0.493 \cdot 1.0 \cdot 1.0 \cdot 1.0 \cdot 0.85 = 3.9 \cdot 10^6 \text{ cycles}$

## MLG™

Given				
Load Details	Steady Load	Inside Diameter, $D_i$	1.25 inch	$\frac{B}{D_i} = \frac{2.50}{1.25} = 2.0$
	Shaft oscillating	Length, B	2.50 inch	
Shaft	Mild Steel, $R_a = 32 \mu\text{inch}$	Bearing Load, F	40,000 pounds	
Environment	Ambient Temperature = 120 °F	Frequency, $N_{osc}$	20 cycles/min.	
		Amplitude, $\phi$	30°	

### Calculation Constants and Application Factors

Specific Load Limit, P	20,000 psi	(Table 7, Page 25)
B/ $D_i$ Factor, $a_{B/D_i}$	1.25	(Fig. 8, Page 25)
Temperature Factor, $a_T$	1.0	(Fig. 11, Page 26)
Mating Material Factor, $a_M$	1.0	(Table 8, Page 26)
Mating Surface Factor, $a_S$	0.6	(Fig. 12, Page 27)
Bearing Size Factor, $a_B$	0.99	(Fig. 14, Page 28)
Cyclic Life Factor, $Q_{MLG}$	$4 \cdot 10^{10}$ psi-fpm	(Table 6, Page 24)

Calculation	Reference	Value
Specific Load, P [N/mm <sup>2</sup> ] or [psi]	(5.2.1), Page 22	$P = \frac{F}{D_i \cdot B} = \frac{40,000}{1.25 \cdot 2.50} = 12,800 \text{ psi}$
Sliding Speed, V [m/s] or [fpm]	(5.3.1), Page 23	$V = \frac{D_i \cdot \pi \cdot N}{12} = \frac{1.25 \cdot \pi \cdot 6.667}{12} = 2.182 \text{ fpm}$ <span style="float: right;"><math>(N = \frac{4 \cdot \phi \cdot N_{osc}}{360} = 6.667 \text{ rpm})</math></span>
PV Factor, PV [N/mm <sup>2</sup> ·m/s] or [psi·fpm]	(5.4.1), Page 23	$PV = P \cdot V = 12,800 \cdot 2.182 = 27,930 \text{ psi} \cdot \text{fpm}$
High Load Factor, $a_E$	(5.5.4), Page 24	$a_E = \left( \frac{P_{lim} - P}{P_{lim}} \right)^{a_{B/D_i}} = \left( \frac{20,000 - 12,800}{20,000} \right)^{1.25} = 0.279$
Life, $L_O$ [cycles]	(5.5.1), Page 24	$L_O = \frac{Q_{GM}}{PV} \cdot a_E \cdot a_T \cdot a_M \cdot a_S \cdot a_B = \frac{4 \cdot 10^{10}}{27,930} \cdot 0.279 \cdot 1.0 \cdot 1.0 \cdot 0.6 \cdot 0.99 = 2.3 \cdot 10^5 \text{ cycles}$

## 5.7 Misalignment

Bearings operating with proper shaft alignment are uniformly loaded along their length as shown in Fig. 15. In the right side of Fig. 15 is a top view of the contact area. Shaft misalignment reduces the contact area and shifts the bearing pressure distribution to one end of the bearing, as illustrated in Fig. 16. With substantial mis-

alignment the contact area reduces to a parabolic shape as shown in Fig. 17. The concentrated edge pressure due to the excessive misalignment can cause bearing failure. When the edge pressure produces stresses that approach or exceed the compressive strength of the material, fracture may occur.

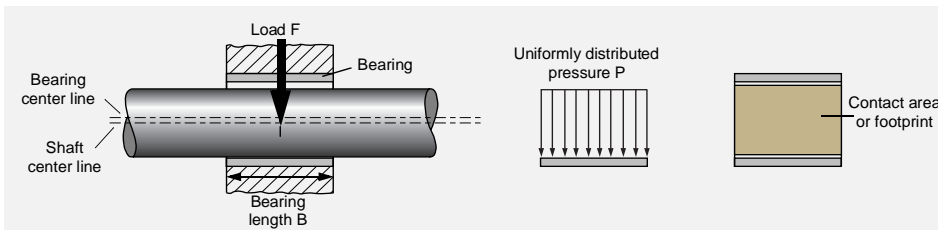

Fig. 15: Properly aligned shaft

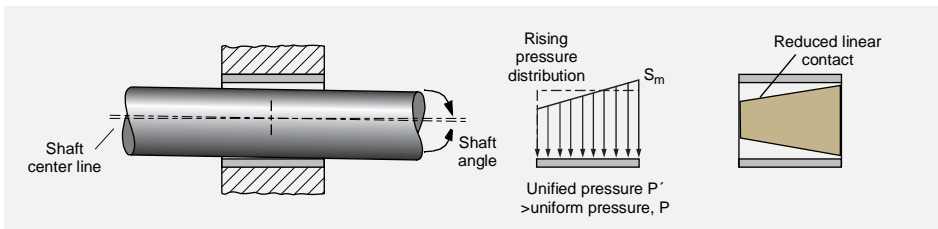

Fig. 16: Slight misalignment

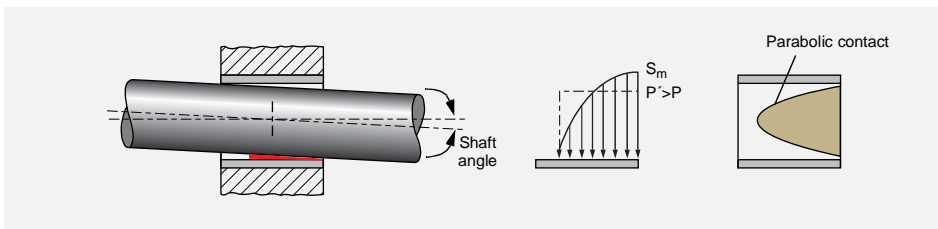

Fig. 17: Substantial misalignment

If it is known from experience that misalignment and/or shaft deflections are minimal, less than 0.2%, (0.002 mm/mm of length [0.002 inch/inch of length]), for highly loaded, very low speed applications, then the following misalignment considerations can be ignored.

Misalignment tests were conducted on GAR-MAX bearings to determine the maximum edge stresses that may occur under varying amounts of misalignment. Fig. 18 and Fig. 19 show the relationship of the calculated edge stress,  $S_m$ , relative to the

applied unit load,  $P$ , for two levels of misalignment (0.6% and 1.0%) and two length-to-diameter ratios ( $B/D_i = 0.5$  and  $B/D_i = 1.0$ ). For static loading, or static combined with shock loading, if the edge stress,  $S_m$ , exceeds the acceptable maximum of 345 N/mm<sup>2</sup> [50,000 psi] for GAR-MAX and MLG or 517 N/mm<sup>2</sup> [75,000 psi] for HSG, then a redesign of the bearing is required.

GAR-FIL is not recommended for applications when significant misalignment is anticipated.



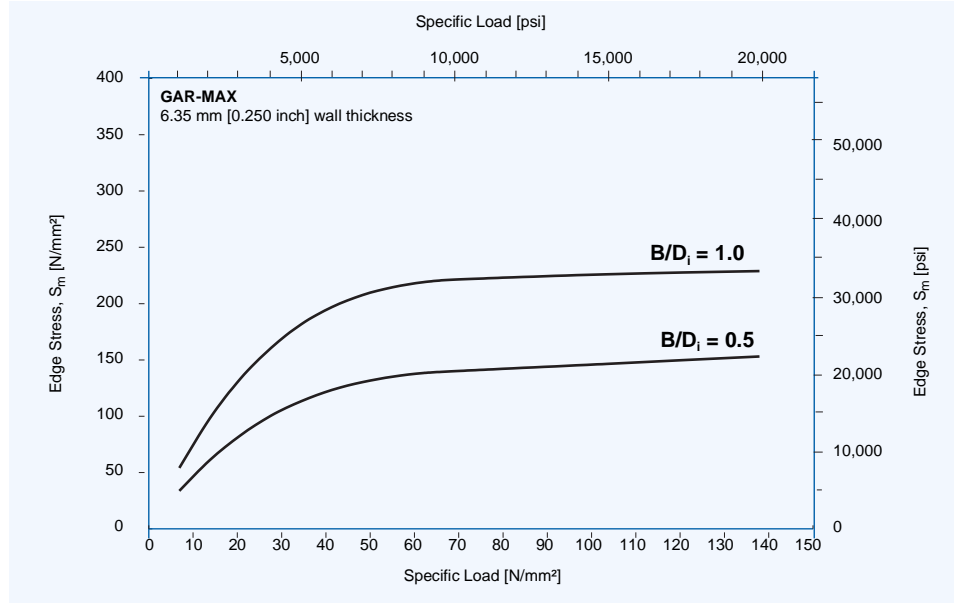

Fig. 18: Edge Stress for 0.6% Misalignment

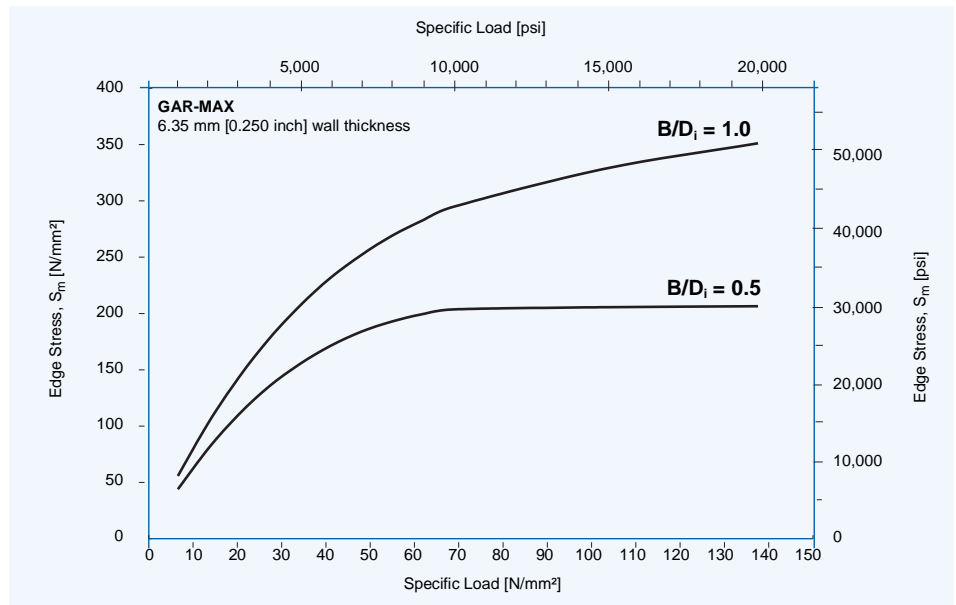

Fig. 19: Edge Stress for 1.0% Misalignment

## 6 Installation and Machining

### 6.1 Installation

The retention of GGB filament wound bearings in metal housings is excellent due to the high material stiffness and a thermal expansion rate similar to steel. The press fits used for bronze bearings are adequate for filament wound bearings in most cases.

The bearing will close in by an amount equal to the measure of interference with the housing. This close-in must be considered when calculating the installed bore and corresponding shaft diameter.

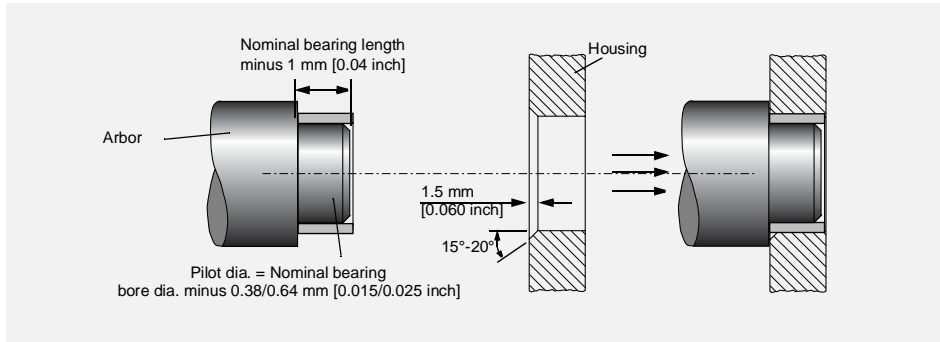

Fig. 20: Fitting of bearings

### 6.2 Machining

#### Length

Abrasive cut-off wheels produce the best results when cutting lengths of GGB filament wound bearings. When using a lathe to cut off lengths, we recommend using a

carbide tool due to the abrasive nature of the fiberglass/epoxy outer shell. Water mist or exhaust dust collectors should be used to minimize dust in the work area.

#### Outer Diameter

Grinding is the preferred method of altering the OD; however, carbide lathe tools can also be used.

#### Inner Diameter

Only GAR-FIL and HPF bearings can be sized on the ID. We recommend specifying 0.76 mm [0.030 inch] or thicker tape liner when ordering bearings that will be bored. When lathe boring a GAR-FIL or HPF

bearing you should first install the bearing into a rigid housing and bore using high speed and low feed rate. GAR-FIL and HPF bearings can also be reamed and broached.

#### Deburring

Emery cloth is effective in removing burrs from the OD of GGB filament wound bearings. To remove frayed fibers from the ID of GAR-MAX, HSG, MLG and HPM bear-

ings, a small hand held grinder is preferred. The ID of GAR-FIL or HPF bearings can be deburred by a sharp cutting tool or emery cloth.

#### Drilling

Carbide drills should be used for drilling GGB filament wound bearings. When drilling GAR-MAX, HSG, MLG and HPM bear-

ings, the ID must be supported with a mandrel, and a flat tipped drill or end mill should be used.

## 7 Standard Products

### 7.1 GF, GM, HSG, MLG (inch sizes)

#### 1/8" wall series

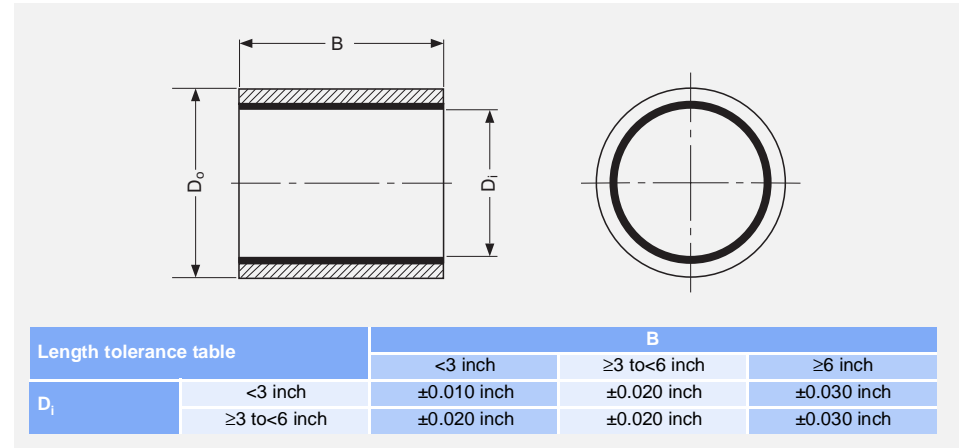

To order, specify bearing material prefix and size number plus suffix for desired length (in multiples of 1/16"). e.g. GM2428-032 is a 1.5" ID x 1.75" OD x 2" long GAR-MAX bearing.

Bearing Part Number	Nominal Size ID x OD D <sub>i</sub> x D <sub>o</sub>	Bearing ID D <sub>i</sub>	Bearing OD D <sub>o</sub>	Recommended Sizes		Running Clearance C <sub>D</sub>
				Shaft Dia. D <sub>J</sub>	Housing Dia. D <sub>H</sub>	
0812-xxx	1/2 x 3/4	0.5040	0.7535	0.5000	0.7500	0.0005
		0.5070	0.7515	0.4995	0.7505	0.0065
1014-xxx	5/8 x 7/8	0.6290	0.8785	0.6250	0.8750	0.0005
		0.6320	0.8765	0.6245	0.8755	0.0065
1216-xxx	3/4 x 1	0.7540	1.0035	0.7500	1.0000	0.0005
		0.7570	1.0015	0.7495	1.0005	0.0065
1418-xxx	7/8 x 1 1/8	0.8790	1.1285	0.8750	1.1250	0.0005
		0.8820	1.1265	0.8745	1.1255	0.0065
1620-xxx	1 x 1 1/4	1.0040	1.2535	1.0000	1.2500	0.0005
		1.0070	1.2515	0.9995	1.2505	0.0065
1822-xxx	1 1/8 x 1 3/8	1.1290	1.3785	1.1250	1.3750	0.0005
		1.1320	1.3765	1.1245	1.3755	0.0065
2024-xxx	1 1/4 x 1 1/2	1.2540	1.5035	1.2500	1.5000	0.0005
		1.2570	1.5015	1.2495	1.5005	0.0065
2226-xxx	1 3/8 x 1 5/8	1.3790	1.6285	1.3750	1.6250	0.0005
		1.3820	1.6265	1.3745	1.6255	0.0065
2428-xxx	1 1/2 x 1 3/4	1.5040	1.7535	1.5000	1.7500	0.0005
		1.5070	1.7515	1.4995	1.7505	0.0065
2630-xxx	1 5/8 x 1 7/8	1.6290	1.8785	1.6250	1.8750	0.0005
		1.6320	1.8765	1.6245	1.8755	0.0065
2832-xxx	1 3/4 x 2	1.7550	2.0035	1.7500	2.0000	0.0015
		1.7580	2.0015	1.7495	2.0005	0.0075
3034-xxx	1 7/8 x 2 1/8	1.8800	2.1285	1.8750	2.1250	0.0015
		1.8830	2.1265	1.8745	2.1255	0.0075
3236-xxx	2 x 2 1/4	2.0055	2.2545	2.0000	2.2500	0.0010
		2.0095	2.2525	1.9995	2.2510	0.0085
3438-xxx	2 1/8 x 2 3/8	2.1305	2.3795	2.1250	2.3750	0.0010
		2.1345	2.3775	2.1245	2.3760	0.0085

Bearing Part Number GF, GM, HSG, MLG	Nominal Size ID x OD D <sub>I</sub> x D <sub>O</sub>	Bearing ID D <sub>I</sub>	Bearing OD D <sub>O</sub>	Recommended Sizes		Running Clearance C <sub>D</sub>
				Shaft Dia. D <sub>J</sub>	Housing Dia. D <sub>H</sub>	
3640-xxx	2 <sup>1</sup> / <sub>4</sub> x 2 <sup>1</sup> / <sub>2</sub>	2.2555	2.5045	2.2500	2.5000	0.0010
		2.2595	2.5025	2.2495	2.5010	0.0085
3842-xxx	2 <sup>3</sup> / <sub>8</sub> x 2 <sup>5</sup> / <sub>8</sub>	2.3805	2.6295	2.3750	2.6250	0.0010
		2.3845	2.6275	2.3740	2.6260	0.0090
4044-xxx	2 <sup>1</sup> / <sub>2</sub> x 2 <sup>3</sup> / <sub>4</sub>	2.5060	2.7545	2.5000	2.7500	0.0015
		2.5100	2.7525	2.4990	2.7510	0.0095
4448-xxx	2 <sup>3</sup> / <sub>4</sub> x 3	2.7560	3.0050	2.7500	3.0000	0.0010
		2.7600	3.0030	2.7490	3.0015	0.0095
4852-xxx	3 x 3 <sup>1</sup> / <sub>4</sub>	3.0065	3.2550	3.0000	3.2500	0.0015
		3.0105	3.2530	2.9990	3.2515	0.0100
5256-xxx	3 <sup>1</sup> / <sub>4</sub> x 3 <sup>1</sup> / <sub>2</sub>	3.2565	3.5055	3.2500	3.5000	0.0010
		3.2605	3.5035	3.2490	3.5020	0.0100
5660-xxx	3 <sup>1</sup> / <sub>2</sub> x 3 <sup>3</sup> / <sub>4</sub>	3.5065	3.7555	3.5000	3.7500	0.0010
		3.5105	3.7535	3.4990	3.7520	0.0100
6064-xxx	3 <sup>3</sup> / <sub>4</sub> x 4	3.7565	4.0055	3.7500	4.0000	0.0010
		3.7605	4.0035	3.7490	4.0020	0.0100
6468-xxx	4 x 4 <sup>1</sup> / <sub>4</sub>	4.0090	4.2570	4.0000	4.2500	0.0020
		4.0140	4.2540	3.9990	4.2520	0.0130
6872-xxx	4 <sup>1</sup> / <sub>4</sub> x 4 <sup>1</sup> / <sub>2</sub>	4.2590	4.5070	4.2500	4.5000	0.0020
		4.2640	4.5040	4.2490	4.5020	0.0130
7276-xxx	4 <sup>1</sup> / <sub>2</sub> x 4 <sup>3</sup> / <sub>4</sub>	4.5090	4.7570	4.5000	4.7500	0.0020
		4.5140	4.7540	4.4990	4.7520	0.0130
7680-xxx	4 <sup>3</sup> / <sub>4</sub> x 5	4.7590	5.0070	4.7500	5.0000	0.0020
		4.7640	5.0040	4.7490	5.0020	0.0130
8084-xxx	5 x 5 <sup>1</sup> / <sub>4</sub>	5.0090	5.2570	5.0000	5.2500	0.0020
		5.0140	5.2540	4.9990	5.2520	0.0130
8488-xxx	5 <sup>1</sup> / <sub>4</sub> x 5 <sup>1</sup> / <sub>2</sub>	5.2590	5.5070	5.2500	5.5000	0.0020
		5.2640	5.5040	5.2490	5.5020	0.0130
8892-xxx	5 <sup>1</sup> / <sub>2</sub> x 5 <sup>3</sup> / <sub>4</sub>	5.5090	5.7570	5.5000	5.7500	0.0020
		5.5140	5.7540	5.4990	5.7520	0.0130
9296-xxx	5 <sup>3</sup> / <sub>4</sub> x 6	5.7590	6.0070	5.7500	6.0000	0.0020
		5.7640	6.0040	5.7490	6.0020	0.0130
96100-xxx	6 x 6 <sup>1</sup> / <sub>4</sub>	6.0120	6.2590	6.0000	6.2500	0.0030
		6.0180	6.2550	5.9985	6.2520	0.0165

All Dimensions in Inches.

Additional sizes available - please consult  
GGB Customer Service.

## GF, GM, HSG, MLG (inch sizes)

### 1/4" wall series

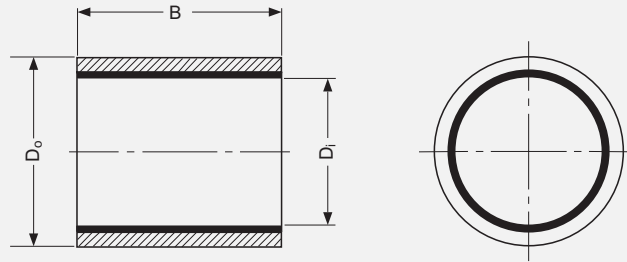

Length tolerance table		B		
		<3 inch	≥3 to<6 inch	≥6 inch
D <sub>i</sub>	<3 inch	±0.010 inch	±0.020 inch	±0.030 inch
	≥3 to<6 inch	±0.020 inch	±0.020 inch	±0.030 inch

To order, specify bearing material prefix and size number plus suffix for desired length (in multiples of 1/16"). e.g. GM2432-032 is a 1.5" ID x 2" OD x 2" long GAR-MAX bearing.

Bearing Part Number GF, GM, HSG, MLG	Nominal Size ID x OD D <sub>i</sub> x D <sub>o</sub>	Bearing ID D <sub>i</sub>	Bearing OD D <sub>o</sub>	Recommended Sizes		Running Clearance C <sub>D</sub>
				Shaft Dia. D <sub>J</sub>	Housing Dia. D <sub>H</sub>	
0816-xxx	1/2 x 1	0.5040	1.0035	0.5000	1.0000	0.0005
		0.5070	1.0015	0.4995	1.0005	0.0065
1018-xxx	5/8 x 1 1/8	0.6290	1.1285	0.6250	1.1250	0.0005
		0.6320	1.1265	0.6245	1.1255	0.0065
1220-xxx	3/4 x 1 1/4	0.7540	1.2535	0.7500	1.2500	0.0005
		0.7570	1.2515	0.7495	1.2505	0.0065
1422-xxx	7/8 x 1 3/8	0.8790	1.3785	0.8750	1.3750	0.0005
		0.8820	1.3765	0.8745	1.3755	0.0065
1624-xxx	1 x 1 1/2	1.0040	1.5035	1.0000	1.5000	0.0005
		1.0070	1.5015	0.9995	1.5005	0.0065
1826-xxx	1 1/8 x 1 5/8	1.1290	1.6285	1.1250	1.6250	0.0005
		1.1320	1.6265	1.1245	1.6255	0.0065
2028-xxx	1 1/4 x 1 3/4	1.2540	1.7535	1.2500	1.7500	0.0005
		1.2570	1.7515	1.2495	1.7505	0.0065
2230-xxx	1 3/8 x 1 7/8	1.3790	1.8785	1.3750	1.8750	0.0005
		1.3820	1.8765	1.3745	1.8755	0.0065
2432-xxx	1 1/2 x 2	1.5040	2.0035	1.5000	2.0000	0.0005
		1.5070	2.0015	1.4995	2.0005	0.0065
2634-xxx	1 5/8 x 2 1/8	1.6290	2.1285	1.6250	2.1250	0.0005
		1.6320	2.1265	1.6245	2.1255	0.0065
2836-xxx	1 3/4 x 2 1/4	1.7550	2.2545	1.7500	2.2500	0.0005
		1.7580	2.2525	1.7495	2.2510	0.0070
3038-xxx	1 7/8 x 2 3/8	1.8800	2.3795	1.8750	2.3750	0.0005
		1.8830	2.3775	1.8745	2.3760	0.0070
3240-xxx	2 x 2 1/2	2.0055	2.5045	2.0000	2.5000	0.0010
		2.0095	2.5025	1.9995	2.5010	0.0085
3442-xxx	2 1/8 x 2 5/8	2.1305	2.6295	2.1250	2.6250	0.0010
		2.1345	2.6275	2.1245	2.6260	0.0085
3644-xxx	2 1/4 x 2 3/4	2.2555	2.7545	2.2500	2.7500	0.0010
		2.2595	2.7525	2.2495	2.7510	0.0085
3846-xxx	2 3/8 x 2 7/8	2.3805	2.8795	2.3750	2.8750	0.0010
		2.3845	2.8775	2.3740	2.8760	0.0090

Bearing Part Number GF, GM, HSG, MLG	Nominal Size ID x OD D <sub>i</sub> x D <sub>o</sub>	Bearing ID D <sub>i</sub>	Bearing OD D <sub>o</sub>	Recommended Sizes		Running Clearance C <sub>D</sub>
				Shaft Dia. D <sub>J</sub>	Housing Dia. D <sub>H</sub>	
4048-xxx	2 1/2 x 3	2.5060 2.5100	3.0050 3.0030	2.5000 2.4990	3.0000 3.0015	0.0010 0.0095
4452-xxx	2 3/4 x 3 1/4	2.7560 2.7600	3.2550 3.2530	2.7500 2.7490	3.2500 3.2515	0.0010 0.0095
4856-xxx	3 x 3 1/2	3.0065 3.0105	3.5055 3.5035	3.0000 2.9990	3.5000 3.5020	0.0010 0.0100
5260-xxx	3 1/4 x 3 3/4	3.2565 3.2605	3.7555 3.7535	3.2500 3.2490	3.7500 3.7520	0.0010 0.0100
5664-xxx	3 1/2 x 4	3.5065 3.5105	4.0055 4.0035	3.5000 3.4990	4.0000 4.0020	0.0010 0.0100
6068-xxx	3 3/4 x 4 1/4	3.7565 3.7605	4.2555 4.2535	3.7500 3.7490	4.2500 4.2520	0.0010 0.0100
6472-xxx	4 x 4 1/2	4.0090 4.0140	4.5070 4.5040	4.0000 3.9990	4.5000 4.5020	0.0020 0.0130
6876-xxx	4 1/4 x 4 3/4	4.2590 4.2640	4.7570 4.7540	4.2500 4.2490	4.7500 4.7520	0.0020 0.0130
7280-xxx	4 1/2 x 5	4.5090 4.5140	5.0070 5.0040	4.5000 4.4990	5.0000 5.0020	0.0020 0.0130
7684-xxx	4 3/4 x 5 1/4	4.7590 4.7640	5.2570 5.2540	4.7500 4.7490	5.2500 5.2520	0.0020 0.0130
8088-xxx	5 x 5 1/2	5.0090 5.0140	5.5070 5.5040	5.0000 4.9990	5.5000 5.5020	0.0020 0.0130
8492-xxx	5 1/4 x 5 3/4	5.2590 5.2640	5.7570 5.7540	5.2500 5.2490	5.7500 5.7520	0.0020 0.0130
8896-xxx	5 1/2 x 6	5.5090 5.5140	6.0070 6.0040	5.5000 5.4990	6.0000 6.0020	0.0020 0.0130
92100-xxx	5 3/4 x 6 1/4	5.7590 5.7640	6.2570 6.2540	5.7500 5.7490	6.2500 6.2520	0.0020 0.0013
96104-xxx	6 x 6 1/2	6.0120 6.0180	6.5090 6.5050	6.0000 5.9985	6.5000 6.5020	0.0030 0.0165

All Dimensions in Inches.

Additional sizes available - please consult GGB Customer Service.

## 7.2 GF, GM, HSG, MLG (metric sizes)

### 2.5 mm wall series

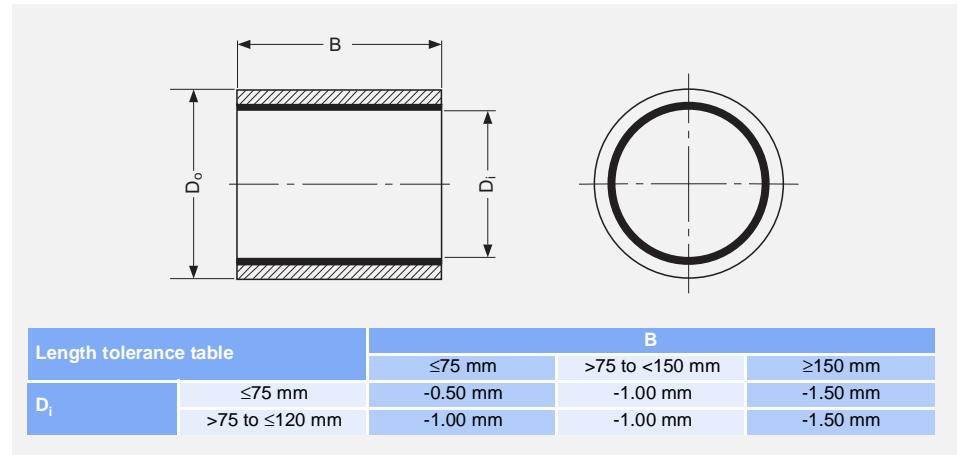

To order, specify bearing ID, OD and length size number (in millimeters) plus material suffix. e.g. 253020GM is a 25 mm ID x 30 mm OD x 20 mm long GAR-MAX bearing.

Bearing Part Number GF, GM, HSG, MLG	Nominal Size ID x OD D <sub>i</sub> x D <sub>o</sub>	Bearing ID D <sub>i</sub>	Bearing OD D <sub>o</sub>	Recommended Sizes		Running Clearance C <sub>D</sub>
				Shaft Dia. [h8] D <sub>J</sub>	Housing Dia. [H7] D <sub>H</sub>	
1217xx	12 x 17	12.110 12.190	17.090 17.040	12.000 11.973	17.000 17.018	0.020 0.195
1520xx	15 x 20	15.110 15.190	20.090 20.040	15.000 14.973	20.000 20.021	0.020 0.198
1621xx	16 x 21	16.110 16.190	21.090 21.040	16.000 15.973	21.000 21.021	0.020 0.198
1823xx	18 x 23	18.110 18.190	23.090 23.040	18.000 17.973	23.000 23.021	0.020 0.198
2025xx	20 x 25	20.110 20.190	25.090 25.040	20.000 19.967	25.000 25.021	0.020 0.204
2227xx	22 x 27	22.110 22.190	27.090 27.040	22.000 21.967	27.000 27.021	0.020 0.204
2530xx	25 x 30	25.110 25.190	30.090 30.040	25.000 24.967	30.000 30.021	0.020 0.204
2833xx	28 x 33	28.115 28.195	33.095 33.045	28.000 27.967	33.000 33.025	0.020 0.208
3035xx	30 x 35	30.115 30.195	35.095 35.045	30.000 29.967	35.000 35.025	0.020 0.208
3540xx	35 x 40	35.115 35.195	40.095 40.045	35.000 34.961	40.000 40.025	0.020 0.214
4045xx	40 x 45	40.115 40.195	45.095 45.045	40.000 39.961	45.000 45.025	0.020 0.214
4550xx	45 x 50	45.125 45.225	50.100 50.050	45.000 44.961	50.000 50.025	0.025 0.239
5055xx	50 x 55	50.125 50.225	55.100 55.055	50.000 49.961	55.000 55.030	0.025 0.239
5560xx	55 x 60	55.140 55.240	60.115 60.065	55.000 54.954	60.000 60.030	0.025 0.251
6065xx	60 x 65	60.140 60.240	65.115 65.065	60.000 59.954	65.000 65.030	0.025 0.251
6570xx	65 x 70	65.140 65.240	70.115 70.065	65.000 64.954	70.000 70.030	0.025 0.251

Bearing Part Number GF, GM, HSG, MLG	Nominal Size ID x OD D <sub>i</sub> x D <sub>o</sub>	Bearing ID D <sub>i</sub>	Bearing OD D <sub>o</sub>	Recommended Sizes		Running Clearance C <sub>D</sub>
				Shaft Dia. [h8] D <sub>J</sub>	Housing Dia. [H7] D <sub>H</sub>	
7075xx	70 x 75	70.145 70.245	75.115 75.065	70.000 69.954	75.000 75.030	0.030 0.256
7580xx	75 x 80	75.165 75.265	80.125 80.070	75.000 74.954	80.000 80.030	0.040 0.271
8085xx	80 x 85	80.165 80.265	85.125 85.075	80.000 79.954	85.000 85.035	0.040 0.271
8590xx	85 x 90	85.165 85.265	90.125 90.075	85.000 84.946	90.000 90.035	0.040 0.279
9095xx	90 x 95	90.175 90.275	95.135 95.085	90.000 89.946	95.000 95.035	0.040 0.279
95100xx	95 x 100	95.175 95.300	100.135 100.085	95.000 94.946	100.000 100.035	0.040 0.304
100105xx	100 x 105	100.175 100.300	105.135 105.085	100.000 99.946	105.000 105.035	0.040 0.304
110115xx	110 x 115	110.175 110.300	115.135 115.080	110.000 109.946	115.000 115.035	0.040 0.309
120125xx	120 x 125	120.205 120.330	125.165 125.105	120.000 119.946	125.000 125.040	0.040 0.319
130135xx	130 x 135	130.205 130.330	135.165 135.090	130.000 129.937	135.000 135.040	0.040 0.343
140145xx	140 x 145	140.205 140.330	145.165 145.090	140.000 139.937	145.000 145.040	0.040 0.343
150155xx	150 x 155	150.205 150.330	155.165 155.090	150.000 149.937	155.000 155.040	0.040 0.343

All Dimensions in Millimeters.

Additional sizes available - please consult  
GGB Customer Service.



## GF, GM, HSG, MLG (metric sizes)

### 5 mm wall series

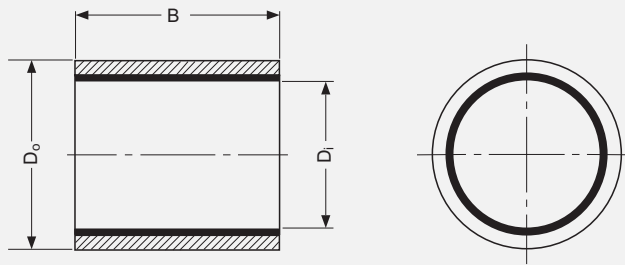

Length tolerance table		B		
		≤75 mm	>75 to <150 mm	≥150 mm
D <sub>i</sub>	≤75 mm	-0.50 mm	-1.00 mm	-1.50 mm
	>75 to ≤120 mm	-1.00 mm	-1.00 mm	-1.50 mm

To order, specify bearing ID, OD and length size number (in millimeters) plus material suffix. e.g. 253520GM is a 25 mm ID x 35 mm OD x 20 mm long GAR-MAX bearing.

Bearing Part Number GF, GM, HSG, MLG	Nominal Size ID x OD D <sub>i</sub> x D <sub>o</sub>	Bearing ID D <sub>i</sub>	Bearing OD D <sub>o</sub>	Recommended Sizes		Running Clearance C <sub>D</sub>
				Shaft Dia. [h8] D <sub>J</sub>	Housing Dia. [H7] D <sub>H</sub>	
1222xx	12 x 22	12.110 12.190	22.090 22.040	12.000 11.973	22.000 22.021	0.020 0.198
1525xx	15 x 25	15.110 15.190	25.090 25.040	15.000 14.973	25.000 25.021	0.020 0.198
1626xx	16 x 26	16.110 16.190	26.090 26.040	16.000 15.973	26.000 26.021	0.020 0.198
1828xx	18 x 28	18.110 18.190	28.090 28.040	18.000 17.973	28.000 28.021	0.020 0.198
2030xx	20 x 30	20.110 20.190	30.090 30.040	20.000 19.967	30.000 30.021	0.020 0.204
2232xx	22 x 32	22.115 22.195	32.095 32.045	22.000 21.967	32.000 32.025	0.020 0.208
2535xx	25 x 35	25.115 25.195	35.095 35.045	25.000 24.967	35.000 35.025	0.020 0.208
2838xx	28 x 38	28.115 28.195	38.095 38.045	28.000 27.967	38.000 38.025	0.020 0.208
3040xx	30 x 40	30.115 30.195	40.095 40.045	30.000 29.967	40.000 40.025	0.020 0.208
3545xx	35 x 45	35.115 35.195	45.095 45.045	35.000 34.961	45.000 45.025	0.020 0.214
4050xx	40 x 50	40.115 40.195	50.095 50.045	40.000 39.961	50.000 50.025	0.020 0.214
4555xx	45 x 55	45.130 45.230	55.105 55.055	45.000 44.961	55.000 55.030	0.025 0.244
5060xx	50 x 60	50.130 50.230	60.105 60.055	50.000 49.961	60.000 60.030	0.025 0.244
5565xx	55 x 65	55.140 55.240	65.115 65.065	55.000 54.954	65.000 65.030	0.025 0.251
6070xx	60 x 70	60.140 60.240	70.115 70.065	60.000 59.954	70.000 70.030	0.025 0.251
6575xx	65 x 75	65.140 65.240	75.115 75.065	65.000 64.954	75.000 75.030	0.025 0.251

Bearing Part Number GF, GM, HSG, MLG	Nominal Size ID x OD D <sub>i</sub> x D <sub>o</sub>	Bearing ID D <sub>i</sub>	Bearing OD D <sub>o</sub>	Recommended Sizes		Running Clearance C <sub>D</sub>
				Shaft Dia. [h8] D <sub>J</sub>	Housing Dia. [H7] D <sub>H</sub>	
7080xx	70 x 80	70.145 70.245	80.115 80.065	70.000 69.954	80.000 80.030	0.030 0.256
7585xx	75 x 85	75.165 75.265	85.125 85.075	75.000 74.954	85.000 85.035	0.040 0.271
8090xx	80 x 90	80.165 80.265	90.125 90.075	80.000 79.954	90.000 90.035	0.040 0.271
8595xx	85 x 95	85.165 85.265	95.125 95.075	85.000 84.946	95.000 95.035	0.040 0.279
90100xx	90 x 100	90.175 90.275	100.135 100.085	90.000 89.946	100.000 100.035	0.040 0.279
95105xx	95 x 105	95.175 95.300	105.135 105.085	95.000 94.946	105.000 105.035	0.040 0.304
100110xx	100 x 110	100.175 100.300	110.135 110.085	100.000 99.946	110.000 110.035	0.040 0.304
110120xx	110 x 120	110.175 110.300	120.135 120.085	110.000 109.946	120.000 120.035	0.040 0.304
120130xx	120 x 130	120.205 120.330	130.165 130.090	120.000 119.946	130.000 130.040	0.040 0.334
130140xx	130 x 140	130.205 130.330	140.165 140.090	130.000 129.937	140.000 140.040	0.040 0.343
140150xx	140 x 150	140.205 140.330	150.165 150.090	140.000 139.937	150.000 150.040	0.040 0.343
150160xx	150 x 160	150.205 150.330	160.165 160.090	150.000 149.937	160.000 160.040	0.040 0.343

All Dimensions in Millimeters.

Additional sizes available - please consult  
GGB Customer Service.

## 7.3 MEGALIFE XT, Thrust Bearings, Inch sizes

To order, specify MWXT size number plus suffix for desired thickness (0.062, 0.080, 0.125). e.g. MWXT1632-.080 is a 1" ID x 2" OD x 0.080" thick **MEGALIFE XT** thrust bearing.

Part Number	Nominal Size ID x OD	Washer ID	Washer OD	Nominal Thickness
MWXT0816-.xxx	1/2 x 1	0.505 0.525	1.000 0.980	0.062, 0.080
MWXT1020-.xxx	5/8 x 1 1/4	0.630 0.650	1.250 1.230	0.062, 0.080, 0.125
MWXT1224-.xxx	3/4 x 1 1/2	0.755 0.775	1.500 1.480	0.062, 0.080, 0.125
MWXT1428-.xxx	7/8 x 1 3/4	0.880 0.900	1.750 1.730	0.062, 0.080, 0.125
MWXT1632-.xxx	1 x 2	1.005 1.025	2.000 1.980	0.062, 0.080, 0.125
MWXT1834-.xxx	1 1/8 x 2 1/8	1.130 1.150	2.125 2.105	0.062, 0.080, 0.125
MWXT2036-.xxx	1 1/4 x 2 1/4	1.255 1.275	2.250 2.230	0.062, 0.080, 0.125
MWXT2238-.xxx	1 3/8 x 2 3/8	1.380 1.400	2.375 2.355	0.062, 0.080, 0.125
MWXT2440-.xxx	1 1/2 x 2 1/2	1.505 1.525	2.500 2.480	0.062, 0.080, 0.125
MWXT2642-.xxx	1 5/8 x 2 5/8	1.630 1.650	2.625 2.605	0.062, 0.080, 0.125
MWXT2844-.xxx	1 3/4 x 2 3/4	1.755 1.775	2.750 2.730	0.062, 0.080, 0.125
MWXT3248-.xxx	2 x 3	2.005 2.025	3.000 2.980	0.062, 0.080, 0.125
MWXT3652-.xxx	2 1/4 x 3 1/4	2.255 2.275	3.250 3.230	0.062, 0.080, 0.125
MWXT4060-.xxx	2 1/2 x 3 3/4	2.505 2.525	3.750 3.730	0.062, 0.080, 0.125
MWXT4464-.xxx	2 3/4 x 4	2.755 2.775	4.000 3.980	0.062, 0.080, 0.125
MWXT4872-.xxx	3 x 4 1/2	3.005 3.025	4.500 4.480	0.062, 0.080, 0.125

All Dimensions in Inches.

Additional sizes available - please consult GGB Customer Service.

## 7.4 MEGALIFE XT, Thrust Bearings, Metric sizes

To order, specify MWXTM size number plus suffix for desired thickness (1.5; 2.0; 3.0).

e.g. MWXTM2244-2.0 is a 22 mm ID x 44 mm OD x 2 mm thick **MEGALIFE XT** thrust bearing.

Part Number	Nominal Size ID x OD	Washer ID	Washer OD	Nominal Thickness
MWXTM1224-x,x	12 x 24	12.25 12.75	24.00 23.50	1.5, 2.0 mm
MWXTM1530-x,x	15 x 30	15.25 15.75	30.00 29.50	1.5, 2.0, 3.0 mm
MWXTM1836-x,x	18 x 36	18.25 18.75	36.00 35.50	1.5, 2.0, 3.0 mm
MWXTM2040-x,x	20 x 40	20.25 20.75	40.00 39.50	1.5, 2.0, 3.0 mm
MWXTM2244-x,x	22 x 44	22.25 22.75	44.00 43.50	1.5, 2.0, 3.0 mm
MWXTM2550-x,x	25 x 50	25.25 25.75	50.00 49.50	1.5, 2.0, 3.0 mm
MWXTM3055-x,x	30 x 55	30.25 30.75	55.00 54.50	1.5, 2.0, 3.0 mm
MWXTM3560-x,x	35 x 60	35.25 35.75	60.00 59.50	1.5, 2.0, 3.0 mm
MWXTM4065-x,x	40 x 65	40.25 40.75	65.00 64.50	1.5, 2.0, 3.0 mm
MWXTM4570-x,x	45 x 70	45.25 45.75	70.00 69.50	1.5, 2.0, 3.0 mm
MWXTM5075-x,x	50 x 75	50.25 50.75	75.00 74.50	1.5, 2.0, 3.0 mm
MWXTM5580-x,x	55 x 80	55.25 55.75	80.00 79.50	1.5, 2.0, 3.0 mm
MWXTM6085-x,x	60 x 85	60.25 60.75	85.00 84.50	1.5, 2.0, 3.0 mm
MWXTM6595-x,x	65 x 95	65.25 65.75	95.00 94.50	1.5, 2.0, 3.0 mm
MWXTM70100-x,x	70 x 100	70.25 70.75	100.00 99.50	1.5, 2.0, 3.0 mm
MWXTM75115-x,x	75 x 115	75.25 75.75	115.00 114.50	1.5, 2.0, 3.0 mm

All Dimensions in Millimeters.

Additional sizes available - please consult GGB Customer Service.

# 8 Data Sheet

## 8.1 Data for bearing design calculations

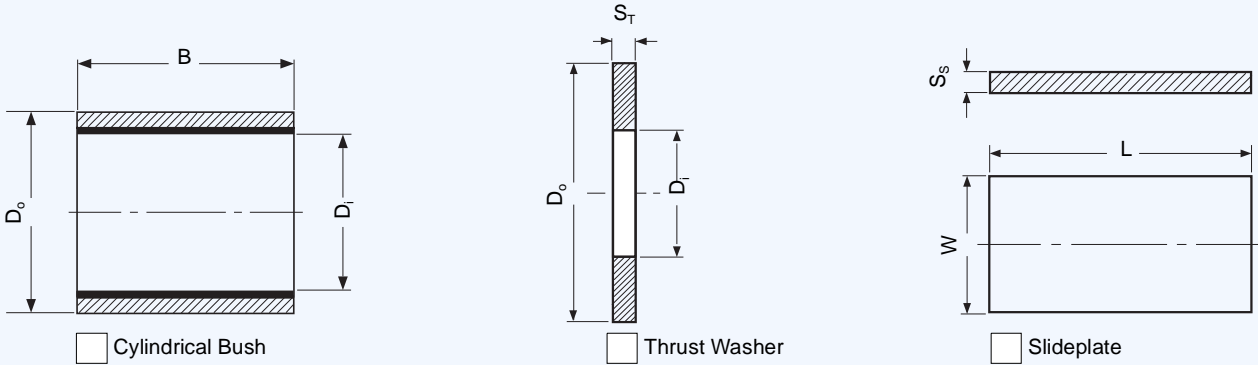

Cylindrical Bush     
  Thrust Washer     
  Slideplate

Rotational movement   
  Steady load           
  Rotating load           
  Oscillating movement   
  Linear movement

Existing Design           
  New Design

Quantity

**Dimensions**

Inside Diameter	$D_i$	<input type="text"/>
Outside Diameter	$D_o$	<input type="text"/>
Length	$B$	<input type="text"/>
Shaft	$D_J$	<input type="text"/>
Bearing Housing	$D_H$	<input type="text"/>
Length of slideplate	$L$	<input type="text"/>
Width of slideplate	$W$	<input type="text"/>
Thickness of slideplate	$S_s$	<input type="text"/>
Thickness of washer	$S_T$	<input type="text"/>

**Load**

Radial load	$F$	<input type="text"/>
or specific load (pressure)	$P$	<input type="text"/>

**Movement**

Rotational speed	$N$ [1/min]	<input type="text"/>
Speed	$V$	<input type="text"/>
Length of Stroke	$L_S$	<input type="text"/>
Frequency of Stroke	[1/min]	<input type="text"/>
Oscillating cycle	$\phi$ [°]	<input type="text"/>
Oscillating frequency	$N_{osc}$ [1/min]	<input type="text"/>

**Operating Environment**

Ambient temperature	$T_{amb}$ [°]	<input type="text"/>
Max. temperature	$T_{max.}$ [°]	<input type="text"/>
Min. temperature	$T_{min.}$ [°]	<input type="text"/>
Process Fluid (chemical)		<input type="text"/>
Lubricant		<input type="text"/>
Contaminents		<input type="text"/>

**Mating surface**

Material	<input type="text"/>
Hardness	<input type="text"/>
Surface finish	<input type="text"/>
Housing Material	<input type="text"/>

**Service hours per day**

Continuous operation	<input type="text"/>
Intermittent operation	<input type="text"/>
Operating time	<input type="text"/>
Days per year	<input type="text"/>

**Service life**

Required service life, cycles	$L_Q$	<input type="text"/>
-------------------------------	-------	----------------------

Company: \_\_\_\_\_ Contact: \_\_\_\_\_  
 Address: \_\_\_\_\_ Title: \_\_\_\_\_  
 City: \_\_\_\_\_ State: \_\_\_\_\_ Postal Code: \_\_\_\_\_  
 Phone: \_\_\_\_\_ Fax: \_\_\_\_\_ Cell: \_\_\_\_\_  
 E-Mail: \_\_\_\_\_

## 9 Other GGB Bearing Materials

Whatever your application requires, GGB offers the solution with its wide range of bearing materials:

**EP** - self-lubricating injection molded thermoplastic (nylon + PTFE + glass fibers + graphite). Available in stock sizes. Special sizes and shapes made to order.

**MF41** - self-lubricating injection molded thermoplastic (PBT + bronze powder + PTFE). Available in stock sizes. Special sizes and shapes made to order.

**DP4** - self-lubricating lead-free metal-polymer (steel backing with porous bronze sinter + PTFE + CaF<sub>2</sub> + polymer fibers) for lubricated and dry applications. Standard sizes, special sizes and shapes made to order.

**DU** - self-lubricating metal-polymer (steel backing with porous bronze sinter + PTFE + lead) for dry and lubricated applications. Available in stock sizes. Special sizes and shapes made to order.

**DU-B** - self-lubricating, corrosion resistant metal-polymer (bronze backing with porous bronze sinter + PTFE + lead) for dry and lubricated applications. Standard sizes, special sizes and shapes made to order.

**DX** - marginally lubricated metal-polymer (steel backing with porous bronze sinter + acetal) for grease and oil lubricated applications. Available in stock sizes. Special sizes and shapes made to order.

**HX** - marginally lubricated metal-polymer (steel backing with porous bronze sinter + PEEK + PTFE + fillers) for grease and oil lubricated applications. Standard sizes, special sizes and shapes made to order.

...and many more. Visit us on the internet:  
[www.ggbearings.com](http://www.ggbearings.com)

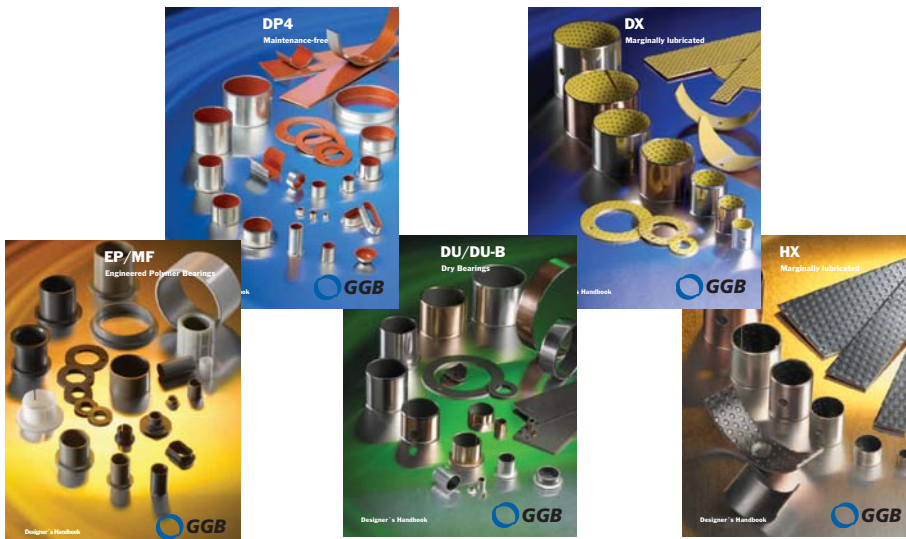

---

## 9 Other GGB Bearing Materials

Your notes:

The information in this bulletin should be used as an informational guide for your consideration, investigation and verification. This information does not constitute a warranty or representation, and we assume no legal responsibility or obligation with respect thereto and the use to which such information may be put. GGB generally warrants, as set forth below, that products described in this brochure are free from defects in workmanship and material, but unless expressly agreed in writing GGB gives no warranty that these products are suitable for any particular purpose or for use under any specific conditions notwithstanding that such purpose would appear to be covered by this publication.

#### **GGB STANDARD WARRANTY AND LIMITATION OF LIABILITY.**

Seller warrants that if any product of its manufacture upon examination is found by a Seller's representative to be defective in either workmanship or material under normal use and service Seller, at its option, will repair or replace same free of charge including lowest transportation charges but not cost of installation or removal or will refund the purchase price thereof, provided that Seller receives written notification of a claim specifying the defect within ninety (90) days from date of distributor sale or one (1) year from date of factory shipment, whichever occurs first. In no event shall Seller be liable for any claims, whether arising from breach of contract or warranty or claims of negligence or negligent manufacture, in excess of the purchase price. ALL OTHER WARRANTIES EXPRESSED AND IMPLIED INCLUDING ANY WARRANTIES OF MERCHANTABILITY AND FITNESS FOR PARTICULAR USE ARE HEREBY DISCLAIMED. The foregoing expresses all of Seller's obligations and liabilities with respect to the quality of items furnished by it and it shall under no circumstances be liable for consequential, collateral or special losses or damages.

**GAR-MAX®** is a trademark of GGB.

**GAR-FIL®** is a trademark of GGB.

**HSG™** is a trademark of GGB.

**MLG™** is a trademark of GGB.

**HPM™** is a trademark of GGB.

**HPF™** is a trademark of GGB.

**MEGALife® XT** is a trademark of GGB.